

UNITED STATES
SECURITIES AND EXCHANGE COMMISSION
WASHINGTON, D.C. 20549

FORM 8-K

CURRENT REPORT

Pursuant to Section 13 or 15(d) of the Securities Exchange Act of 1934

Date of Report (Date of earliest event reported): August 08, 2023

DIODES INCORPORATED

(Exact name of Registrant as Specified in Its Charter)

Delaware
(State or Other Jurisdiction
of Incorporation)

002-25577
(Commission File Number)

95-2039518
(IRS Employer
Identification No.)

4949 Hedgcoxe Road, Suite 200
Plano, Texas
(Address of Principal Executive Offices)

75024
(Zip Code)

Registrant's Telephone Number, Including Area Code: 972 987-3900

(Former Name or Former Address, if Changed Since Last Report)

Check the appropriate box below if the Form 8-K filing is intended to simultaneously satisfy the filing obligation of the registrant under any of the following provisions:

- Written communications pursuant to Rule 425 under the Securities Act (17 CFR 230.425)
- Soliciting material pursuant to Rule 14a-12 under the Exchange Act (17 CFR 240.14a-12)
- Pre-commencement communications pursuant to Rule 14d-2(b) under the Exchange Act (17 CFR 240.14d-2(b))
- Pre-commencement communications pursuant to Rule 13e-4(c) under the Exchange Act (17 CFR 240.13e-4(c))

Securities registered pursuant to Section 12(b) of the Act:

Title of each class	Trading Symbol(s)	Name of each exchange on which registered
Common Stock, Par Value \$0.66 2/3	DIOD	The Nasdaq Stock Market LLC

Indicate by check mark whether the registrant is an emerging growth company as defined in Rule 405 of the Securities Act of 1933 (§ 230.405 of this chapter) or Rule 12b-2 of the Securities Exchange Act of 1934 (§ 240.12b-2 of this chapter).

Emerging growth company

If an emerging growth company, indicate by check mark if the registrant has elected not to use the extended transition period for complying with any new or revised financial accounting standards provided pursuant to Section 13(a) of the Exchange Act.

Item 2.02 Results of Operations and Financial Condition.

On August 8, 2023, Diodes Incorporated (the “Company”) issued a press release announcing its second quarter 2023 financial results. A copy of the press release is furnished as Exhibit 99.1.

In the press release, the Company utilizes financial measures and terms not calculated in accordance with generally accepted accounting principles in the United States (“GAAP”) in order to provide investors with an alternative method for assessing the Company’s operating results in a manner that enables investors to more thoroughly evaluate its current performance as compared to past performance. The Company also believes these non-GAAP measures provide investors with a more informed baseline for modeling the Company’s future financial performance. Management uses these non-GAAP measures for the same purpose. The Company believes that investors should have access to the same set of tools that management uses in analyzing results. These non-GAAP measures should be considered in addition to results prepared in accordance with GAAP, but should not be considered a substitute for or superior to GAAP results and may differ from similar measures used by other companies. See Exhibit 99.1 for a description and reconciliation with GAAP of the non-GAAP measures used.

The information furnished in this Item 2.02, including the exhibit incorporated by reference, will not be treated as “filed” for the purposes of Section 18 of the Securities Exchange Act of 1934, as amended (the “Exchange Act”), or otherwise subject to the liabilities of that section. This information will not be deemed incorporated by reference into any filing under the Securities Act of 1933, as amended (the “Securities Act”), or into another filing under the Exchange Act, unless that filing expressly refers to specific information in this Report.

Item 7.01 Regulation FD Disclosure.

The press release furnished as Exhibit 99.1 also provides an update on the Company’s business outlook, that is intended to be within the safe harbor provided by the Private Securities Litigation Reform Act of 1995 (the “Act”) as comprising forward looking statements within the meaning of the Act.

The information furnished in this Item 7.01, including the exhibit incorporated by reference, will not be treated as “filed” for the purposes of Section 18 of the Exchange Act, or otherwise subject to the liabilities of that section. This information will not be deemed incorporated by reference into any filing under the Securities Act, or into another filing under the Exchange Act, unless that filing expressly refers to specific information in this Report.

Item 8.01 Other Events.

From time to time, Diodes Incorporated (the “Company”) may give corporate presentations to its customers, suppliers and other related interested parties. Copies of the Company’s corporate presentation slides, updated on August 8, 2023, are attached herewith as Exhibit 99.2 and Exhibit 99.3. Exhibit 99.2 provides an update focused on the Company’s second quarter 2023 financial results and Exhibit 99.3 is used in the Company’s investor relations presentations.

Forward-Looking Statements

Statements in this Current Report on Form 8-K (including in the documents attached as Exhibit 99.1, Exhibit 99.2 and Exhibit 99.3 contain forward-looking statements that involve future risks and uncertainties as contemplated by the safe harbor provided by the Private Securities Litigation Reform Act of 1995. All statements, other than statements of historical facts, included in this Current Report on Form 8-K (including the documents attached as Exhibit 99.1, Exhibit 99.2 and Exhibit 99.3 should be regarded as “forward-looking statements” and Exhibit 99.1, Exhibit 99.2 and Exhibit 99.3 contain a more detailed listing of the risks and uncertainties associated with those forward-looking statements. Diodes undertakes no obligation to update publicly any forward-looking statements, whether as a result of new information, future events or otherwise, except as required by applicable law.

Item 9.01 Financial Statements and Exhibits.

(d) Exhibits.

<u>Exhibit Number</u>	<u>Description</u>
99.1	Press release dated August 8, 2023.
99.2	Second Quarter 2023 Financial Results.
99.3	Corporate slides for investor relations presentation.
104	Cover Page Interactive Data File (embedded within the Inline XBRL document).

SIGNATURES

Pursuant to the requirements of the Securities Exchange Act of 1934, the registrant has duly caused this report to be signed on its behalf by the undersigned thereunto duly authorized.

DIODES INCORPORATED

Date: August 8, 2023

By: /s/Brett R. Whitmire
Brett R. Whitmire
Chief Financial Officer



Diodes Incorporated Reports Second Quarter Fiscal 2023 Financial Results

Record Automotive and Industrial Product Revenue Drives Record Gross Margin

Plano, Texas – August 8, 2023 -- Diodes Incorporated (Diodes) (Nasdaq: DIOD) today reported its financial results for the second quarter ended June 30, 2023.

Second Quarter Highlights

- Revenue was \$467.2 million, decreasing 6.8 percent from \$501.0 million in the second quarter 2022 and flat with \$467.2 million in the first quarter 2023;
- Automotive and Industrial revenue was a record 48 percent of total product revenue;
- GAAP gross profit was \$195.4 million, decreasing 5.4 percent from \$206.5 million in the second quarter 2022 and up 0.5 percent from \$194.5 million in the first quarter 2023;
- GAAP gross profit margin was a record 41.8 percent, an increase of 60 basis points from 41.2 percent in the second quarter 2022 and up 20 basis points compared to 41.6 percent in the first quarter 2023;
- GAAP net income was \$82.0 million, compared to \$80.2 million in the second quarter 2022 and \$71.2 million in the first quarter 2023;
- Non-GAAP adjusted net income was \$73.3 million, compared to \$86.9 million in the second quarter 2022 and \$73.4 million in the first quarter 2023;
- GAAP EPS was \$1.77 per diluted share, compared to \$1.75 per diluted share in the second quarter 2022 and \$1.54 per diluted share in the first quarter 2023;
- Non-GAAP EPS was \$1.59 per diluted share, compared to \$1.90 per diluted share in the prior year quarter and \$1.59 per diluted share last quarter;
- Excluding \$6.0 million, net of tax, of non-cash share-based compensation expense, both GAAP and non-GAAP earnings per share would have increased by \$0.13 per diluted share;
- EBITDA increased to \$133.5 million, or 28.6 percent of revenue, from \$130.6 million, or 26.1 percent of revenue, in the second quarter 2022 and \$121.8 million, or 26.1 percent of revenue, in the first quarter 2023; and
- Achieved cash flow from operations of \$92.6 million and \$55.6 million of free cash flow, including \$37.0 of capital expenditures. Net cash flow was a negative \$1.2 million, including the pay-down of \$34.4 million of total debt.

Commenting on the results, Dr. Keh-Shew Lu, Chairman, President and Chief Executive Officer, stated, “Even though the recovery in the consumer, computing and communications markets was much slower than expected during the quarter, our achievement of record automotive and industrial product revenue enabled us to maintain revenue flat sequentially and in-line with our guidance, while also delivering record gross margin. This quarter was the sixth consecutive quarter gross margin was above our target model of 40%, and the sixth consecutive quarter automotive and industrial increased as a percentage of revenue.

“Looking forward, we have begun to see early indications of market improvement with inventory days decreasing in the second quarter coupled with an increase in worldwide POS revenue. Although we expect a further reduction in channel inventory into the third quarter, Diodes’ ongoing strategy to improve sales and product mix, including growing revenue contribution from the automotive and industrial markets, positions us to continue achieving our long-term growth and margin targets.”

Second Quarter 2023

Revenue for second quarter 2023 was \$467.2 million, decreasing 6.8 percent from \$501.0 million in the second quarter 2022 and flat with \$467.2 million in the first quarter 2023.

GAAP gross profit for the second quarter 2023 was \$195.4 million, or 41.8 percent of revenue, compared to \$206.5 million, or 41.2 percent of revenue, in the second quarter of 2022 and \$194.5 million, or 41.6 percent of revenue, in the first quarter 2023.

GAAP operating expenses for second quarter 2023 were \$105.8 million, or 22.7 percent of revenue, and on a non-GAAP basis were \$102.0 million, or 21.8 percent of revenue, which excludes \$3.8 million of amortization of acquisition-related intangible asset expenses. GAAP operating expenses in the second quarter 2022 were \$100.3 million, or 20.0 percent of revenue, and in the first quarter 2023 were \$108.0 million, or 23.1 percent of revenue.

Second quarter 2023 GAAP net income was \$82.0 million, or \$1.77 per diluted share, compared to GAAP net income in the second quarter 2022 of \$80.2 million, or \$1.75 per diluted share, and GAAP net income of \$71.2 million, or \$1.54 per diluted share, in the first quarter 2023.

Second quarter 2023 non-GAAP adjusted net income was \$73.3 million, or \$1.59 per diluted share, which excluded, net of tax, \$3.1 million of acquisition-related intangible asset costs, an \$11.7 million gain on an equity investment. This compares to non-GAAP adjusted net income of \$86.9 million, or \$1.90 per diluted share, in the second quarter 2022 and \$73.4 million, or \$1.59 per diluted share, in the first quarter 2023.

The following is an unaudited summary reconciliation of GAAP net income to non-GAAP adjusted net income and per share data, net of tax (*in thousands, except per share data*):

	Three Months Ended June 30, 2023	
GAAP net income	\$	82,020
GAAP diluted earnings per share	\$	1.77
Adjustments to reconcile net income to non-GAAP net income:		
Amortization of acquisition-related intangible assets		3,091
Officer retirement		(46)
Non-cash market-to-market investment value adjustments		(11,732)
Non-GAAP net income	\$	73,333
Non-GAAP diluted earnings per share	\$	1.59

Note: Throughout this release, we refer to "net income attributable to common stockholders" as "net income."

(See the reconciliation tables of GAAP net income to non-GAAP adjusted net income near the end of this release for further details.)

Included in second quarter 2023 GAAP net income and non-GAAP adjusted net income was approximately \$6.0 million, net of tax, of non-cash share-based compensation expense. Excluding share-based compensation expense, both GAAP earnings per share ("EPS") and non-GAAP adjusted EPS would have increased by \$0.13 per diluted share for the second quarter 2023, \$0.14 for second quarter 2022 and \$0.17 for the first quarter 2023.

EBITDA (a non-GAAP measure), which represents earnings before net interest expense, income tax, depreciation and amortization, in second quarter 2023 was \$133.5 million, or 28.6 percent of revenue, increasing from \$130.6 million, or 26.1 percent of revenue, in second quarter 2022 and \$121.8 million, or 26.1 percent of revenue, in first quarter 2023. For a reconciliation of GAAP net income to EBITDA, see the table near the end of this release for further details.

For second quarter 2023, net cash provided by operating activities was \$96.2 million. Net cash flow was a negative \$1.2 million, which includes the pay-down of \$34.4 million of total debt. Free cash flow (a non-GAAP measure) was \$55.6 million, which includes \$37.0 million of capital expenditures.

Balance Sheet

As of June 30, 2023, the Company had approximately \$334 million in cash and cash equivalents, restricted cash, and short-term investments. Total debt (including long-term and short-term) amounted to approximately \$89 million and working capital was approximately \$747 million.

The results announced today are preliminary and unaudited, as they are subject to the Company finalizing its closing procedures and completion of the quarterly review by its independent registered public accounting firm. As such, these results are subject to revision until the Company files its Form 10-Q for the quarter ending June 30, 2023.

Business Outlook

Dr. Lu concluded, "For the third quarter of 2023, we expect revenue to be approximately \$425 million, plus or minus 3 percent, as we expect to continue reducing channel inventory due to the slower recovery in the consumer, computing and communications markets. GAAP gross margin is expected to decrease sequentially to 40.0 percent, plus or minus 1 percent., primarily due to the impact of our manufacturing service agreements but remains at our target model. Non-GAAP operating expenses, which are GAAP operating expenses adjusted for amortization of acquisition-related intangible assets, are expected to be approximately 23.0 percent of revenue, plus or minus 1 percent. We expect net interest expense to be approximately \$1.0 million. Our income tax rate is expected to be 20.0 percent, plus or minus 3 percent, and shares used to calculate diluted EPS for the third quarter are anticipated to be approximately 46.7 million."

Amortization of acquisition-related intangible assets of \$3.1 million, after tax, for previous acquisitions is not included in these non-GAAP estimates.

Conference Call

Diodes will host a conference call on Tuesday, August 8, 2023 at 4:00 p.m. Central Time (5:00 p.m. Eastern Time) to discuss its second quarter financial results. Investors and analysts may join the conference call by dialing **1-833-634-2590**, and international callers may join the teleconference by dialing **+1-412-317-6038**. A telephone replay of the call will be made available approximately two hours after the call and will remain available until August 15, 2023 at midnight Central Time. The replay number is 1-877-344-7529 with a pass code of 9628513. International callers should dial **+1-412-317-0088** and enter the same pass code at the prompt.

Additionally, this conference call will be broadcast live over the Internet and can be accessed by all interested parties on the Investors' section of Diodes' website at <https://investor.diodes.com>. To listen to the live call, please go to the investors' section of Diodes' website and click on the conference call link at least 15 minutes prior to the start of the call to register, download and install any necessary audio software. For those unable to participate during the live broadcast, a replay will be available shortly after the call on Diodes' website for approximately 90 days.

About Diodes Incorporated

Diodes Incorporated (Nasdaq: DIOD), a Standard and Poor's SmallCap 600 and Russell 3000 Index company, delivers high-quality semiconductor products to the world's leading companies in the automotive, industrial, computing, consumer electronics, and communications markets. We leverage our expanded product portfolio of discrete, analog, and mixed-signal products and leading-edge packaging technology to meet customers' needs. Our broad range of application-specific solutions and solutions-focused sales, coupled with worldwide operations of 32 sites, including engineering, testing, manufacturing, and customer service, enables us to be a premier provider for high-volume, high-growth markets. For more information visit www.diodes.com.

Safe Harbor Statement Under the Private Securities Litigation Reform Act of 1995: Any statements set forth above that are not historical facts are forward-looking statements that involve risks and uncertainties that could cause actual results to differ materially from those in the forward-looking statements. Such statements include statements containing forward-looking words such as "expect," "anticipate," "aim," "estimate," and variations thereof, including without limitation statements, whether direct or implied, regarding expectations of that for the third quarter of 2023, we expect revenue to be approximately \$425 million plus or minus 3 percent; we expect GAAP gross margin to be 40.0 percent, plus or minus 1 percent; non-GAAP operating expenses, which are GAAP operating expenses adjusted for amortization of acquisition-related intangible assets, are expected to be approximately 23.0 percent of revenue, plus or minus 1 percent; we expect non-GAAP net interest expense to be approximately \$1.0 million; we expect our income tax rate to be 20.0 percent, plus or minus 3 percent; shares used to calculate diluted EPS for the third quarter are anticipated to be approximately 46.7 million. Potential risks and uncertainties include, but are not limited to, such factors as: the risk that the COVID-19 pandemic may continue and have a material adverse effect on customer demand and staffing of our production, sales and administration facilities; the risk that such expectations may not be met; the risk that the expected benefits of acquisitions may not be realized or that integration of acquired businesses may not continue as rapidly as we anticipate; the risk that the cost, expense, and diversion of management attention associated with the LSC acquisition may be greater than we currently expect; the risk that we may not be able to maintain our current growth strategy or continue to maintain our current performance, costs, and loadings in our manufacturing facilities; the risk that we may not be able to increase our automotive, industrial, or other revenue and market share; risks of domestic and foreign operations, including excessive operating costs, labor shortages, higher tax rates, and our joint venture prospects; the risks of cyclical downturns in the semiconductor industry and of changes in end-market demand or product mix that may affect gross margin or render inventory obsolete; the risk of unfavorable currency exchange rates; the risk that our future outlook or guidance may be incorrect; the risks of global economic weakness or instability in global financial markets; the risks of trade restrictions, tariffs, or embargoes; the risk that the coronavirus outbreak or other similar epidemics may harm our domestic or international business operations to a greater extent than we currently anticipate; the risk of breaches of our information technology systems; and other information, including the "Risk Factors" detailed from time to time in Diodes' filings with the United States Securities and Exchange Commission.

The Diodes logo is a registered trademark of Diodes Incorporated in the United States and other countries.

© 2023 Diodes Incorporated. All Rights Reserved

Company Contact:

Diodes Incorporated
Gurmeet Dhaliwal
Director, IR & Corporate Marketing
P: 408-232-9003
E: Gurmeet_Dhaliwal@diodes.com

Investor Relations Contact:

Shelton Group
Leanne Sievers
President, Investor Relations
P: 949-388-0648
E: lsievers@sheltongroup.com

DIODES INCORPORATED AND SUBSIDIARIES
CONSOLIDATED CONDENSED STATEMENTS OF OPERATIONS
(unaudited)
(in thousands, except per share data)

	Three Months Ended June 30, 2023		Six Months Ended June 30, 2023	
	2023	2022	2023	2022
Net sales	\$ 467,152	\$ 500,972	\$ 934,393	\$ 983,095
Cost of goods sold	271,776	294,446	544,563	579,872
Gross profit	195,376	206,526	389,830	403,223
Operating expenses				
Selling, general and administrative	67,500	69,067	138,491	140,510
Research and development	34,611	30,762	67,843	59,439
Amortization of acquisition-related intangible assets	3,816	3,980	7,668	7,842
Other operating expense (income)	(118)	(3,521)	(166)	(3,864)
Total operating expense	105,809	100,288	213,836	203,927
Income from operations	89,567	106,238	175,994	199,296
Other (expense) income				
Interest income	2,224	861	3,996	1,687
Interest expense	(2,189)	(1,590)	(4,321)	(2,704)
Foreign currency (loss) gain, net	(2,217)	1,819	(4,110)	3,540
Unrealized gain(loss) on investments	12,172	(7,764)	16,061	(13,312)
Other income	1,398	1,647	1,928	3,523
Total other income (expense)	11,388	(5,027)	13,554	(7,266)
Income before income taxes and noncontrolling interest	100,955	101,211	189,548	192,030
Income tax provision	17,224	18,461	33,840	35,107
Net income	83,731	82,750	155,708	156,923
Less net (income) attributable to noncontrolling interest	(1,711)	(2,595)	(2,538)	(4,077)
Net income attributable to common stockholders	\$ 82,020	\$ 80,155	\$ 153,170	\$ 152,846
Earnings per share attributable to common stockholders:				
Basic	\$ 1.79	\$ 1.77	\$ 3.35	\$ 3.38
Diluted	\$ 1.77	\$ 1.75	\$ 3.31	\$ 3.33
Number of shares used in earnings per share computation:				
Basic	45,733	45,265	45,667	45,185
Diluted	46,243	45,841	46,263	45,913

Note: Throughout this release, we refer to "net income attributable to common stockholders" as "net income."

DIODES INCORPORATED AND SUBSIDIARIES
RECONCILIATION OF NET INCOME TO ADJUSTED NET INCOME
(in thousands, except per share data)
(unaudited)

For the three months ended June 30, 2023:

	<u>Operating Expenses</u>	<u>Other (Income) Expense</u>	<u>Income Tax Provision</u>	<u>Net Income</u>
Per-GAAP				\$ 82,020
Diluted earnings per share (per-GAAP)				\$ 1.77
Adjustments to reconcile net income to non-GAAP net income:				
Amortization of acquisition-related intangible assets	3,817		(726)	3,091
Officer retirement	(57)		11	(46)
Non-cash market-to-market investment value adjustments		(12,172)	440	(11,732)
Non-GAAP				\$ 73,333
Diluted shares used in computing earnings per share				46,243
Non-GAAP diluted earnings per share				\$ 1.59

Note: Included in GAAP and non-GAAP net income was approximately \$6.0 million, net of tax, non-cash share-based compensation expense. Excluding share-based compensation expense, both GAAP and non-GAAP diluted earnings per share would have increased by \$0.13 per share.

DIODES INCORPORATED AND SUBSIDIARIES
CONSOLIDATED RECONCILIATION OF NET INCOME TO ADJUSTED NET INCOME – Cont.
(in thousands, except per share data)
(unaudited)

For the three months ended June 30, 2022:

	Operating Expenses	Other Income (Expense)	Income Tax Provision	Net Income
Per-GAAP				\$ 80,155
Diluted earnings per share (Per-GAAP)				1.75
Adjustments to reconcile net income to non-GAAP net income:				
Amortization of acquisition-related intangible assets	3,980		(729)	3,251
Acquisition-related costs	204		(44)	160
Insurance Recovery for Manufacturing Facility	(3,594)		719	(2,875)
Non-cash market-to-market investment value adjustments		7,764	(1,553)	6,211
Non-GAAP				\$ 86,902
Diluted shares used in computing earnings per share				45,841
Non-GAAP diluted earnings per share				\$ 1.90

Note: Included in GAAP and non-GAAP adjusted net income was approximately \$6.6 million, net of tax, non-cash share-based compensation expense. Excluding share-based compensation expense, both GAAP and non-GAAP adjusted diluted earnings per share would have increased by \$0.14 per share.

DIODES INCORPORATED AND SUBSIDIARIES
CONSOLIDATED RECONCILIATION OF NET INCOME TO ADJUSTED NET INCOME – Cont.
(in thousands, except per share data)
(unaudited)

For the six months ended June 30, 2023:

		Six Months Ended June 30, 2023
GAAP net income	\$	153,170
GAAP diluted earnings per share	\$	3.31
Adjustments to reconcile net income to non-GAAP net income:		
Amortization of acquisition-related intangible assets		6,236
Officer retirement		2,230
Non-cash market-to-market investment value adjustments		(14,804)
Non-GAAP net income	\$	146,832
Non-GAAP diluted earnings per share	\$	3.17

Note: Included in GAAP and non-GAAP adjusted net income was approximately \$13.7 million, net of tax, non-cash share-based compensation expense. Excluding share-based compensation expense, both GAAP and non-GAAP adjusted diluted earnings per share would have improved by \$0.30 per share.

DIODES INCORPORATED AND SUBSIDIARIES
CONSOLIDATED RECONCILIATION OF NET INCOME TO ADJUSTED NET INCOME – Cont.
(in thousands, except per share data)
(unaudited)

For the six months ended June 30, 2022:

	Operating Expenses	Other Income (Expense)	Income Tax Provision	Net Income
Per-GAAP				\$ 152,846
Diluted earnings per share (Per-GAAP)				3.33
Adjustments to reconcile net income to non-GAAP net income:				
Amortization of acquisition-related intangible assets	7,842		(1,435)	6,407
Acquisition-related costs	479		(101)	378
Insurance Recovery for Manufacturing Facility	(3,594)		719	(2,875)
Non-cash market-to-market investment value adjustments		13,312	(2,856)	10,456
Non-GAAP				\$ 167,212
Diluted shares used in computing earnings per share				45,913
Non-GAAP diluted earnings per share				\$ 3.64

Note: Included in GAAP and non-GAAP adjusted net income was approximately \$13.0 million, net of tax, non-cash share-based compensation expense. Excluding share-based compensation expense, both GAAP and non-GAAP adjusted diluted earnings per share would have improved by \$0.28 per share.

ADJUSTED NET INCOME AND ADJUSTED EARNINGS PER SHARE

The Company's financial statements present net income and earnings per share that are calculated using accounting principles generally accepted in the United States ("GAAP"). The Company's management makes adjustments to the GAAP measures that it feels are necessary to allow investors and other readers of the Company's financial releases to view the Company's operating results as viewed by the Company's management, board of directors and research analysts in the semiconductor industry. These non-GAAP measures are not prepared in accordance with, and should not be considered alternatives or necessarily superior to, GAAP financial data and may be different from non-GAAP measures used by other companies. Because non-GAAP financial measures are not standardized, it may not be possible to compare these financial measures with other companies' non-GAAP financial measures, even if they have similar names. The explanation of the adjustments made in the table above, are set forth below:

Detail of non-GAAP adjustments:

Amortization of acquisition-related intangible assets – The Company excluded this item, including amortization of developed technologies and customer relationships. The fair value of the acquisition-related intangible assets is amortized using straight-line methods which approximate the proportion of future cash flows estimated to be generated each period over the estimated useful life of the applicable assets. The Company believes that exclusion of this item is appropriate because a significant portion of the purchase price for its acquisitions was allocated to the intangible assets that have short lives and exclusion of the amortization expense allows comparisons of operating results that are consistent over time for both the Company's newly acquired and long-held businesses. In addition, the Company excluded this item because there is significant variability and unpredictability among companies with respect to this expense.

Acquisition related costs – The Company excluded expenses associated with previous acquisitions of that typically consist of advisory, legal and other professional and consulting fees. These costs were expensed as they were incurred and as services were received, and in which the corresponding tax adjustments were made for the non-deductible portions of these expenses. The Company believes the exclusion of the acquisition related costs provides investors with a more accurate reflection of costs likely to be incurred in the absence of an unusual event such as an acquisition and facilitates comparisons with the results of other periods that may not reflect such costs.

Officer retirement – The Company excluded costs related to the retirement of two executives. These costs represent cash payments and the accelerated vesting of previously issued stock awards. The Company feels it is appropriate to exclude these costs since they don't represent ongoing operating expenses and will present investors with a more accurate indication of our continuing operations.

Non-cash mark-to-market investment value adjustments – The Company excluded market to market adjustments on various equity related investments. The Company believes this is not reflective of the ongoing operations and exclusion of this provides investors an enhanced view of the Company's operating results.

Insurance Recovery for Manufacturing Facility – The Company has recorded gains related to insurance recovery for a manufacturing facility in Asia. The Company believes the exclusion of the insurance recovery provides investors with a more accurate reflection of the continuing operations of the Company and facilitates comparisons with the results of other periods which may not reflect such gains.

CASH FLOW ITEMS

Free cash flow (FCF) (Non-GAAP)

FCF for the second quarter of 2023 is a non-GAAP financial measure, which is calculated by subtracting capital expenditures from cash flow from operations. For the second quarter of 2023, FCF was \$55.6 million, which represents the cash and cash equivalents that we are able to generate after taking into account cash outlays required to maintain or expand property, plant and equipment. FCF is important because it allows us to pursue opportunities to develop new products, make acquisitions and reduce debt.

CONSOLIDATED RECONCILIATION OF NET INCOME TO EBITDA

EBITDA represents earnings before net interest expense, income tax provision, depreciation and amortization. Management believes EBITDA is useful to investors because it is frequently used by securities analysts, investors and other interested parties, such as financial institutions in extending credit, in evaluating companies in our industry and provides further clarity on our profitability. In addition, management uses EBITDA, along with other GAAP and non-GAAP measures, in evaluating our operating performance compared to that of other companies in our industry. The calculation of EBITDA generally eliminates the effects of financing, operating in different income tax jurisdictions, and accounting effects of capital spending, including the impact of our asset base, which can differ depending on the book value of assets and the accounting methods used to compute depreciation and amortization expense. EBITDA is not a recognized measurement under GAAP, and when analyzing our operating performance, investors should use EBITDA in addition to, and not as an alternative for, income from operations and net income, each as determined in accordance with GAAP. Because not all companies use identical calculations, our presentation of EBITDA may not be comparable to similarly titled measures used by other companies. For example, our EBITDA takes into account all net interest expense, income tax provision, depreciation and amortization without taking into account any amounts attributable to noncontrolling interest. Furthermore, EBITDA is not intended to be a measure of free cash flow for management's discretionary use, as it does not consider certain cash requirements such as tax and debt service payments.

The following table provides a reconciliation of net income to EBITDA (*in thousands, unaudited*):

	<u>Three Months Ended</u> <u>June 30, 2023</u>		<u>Six Months Ended</u> <u>June 30, 2023</u>	
	<u>2023</u>	<u>2022</u>	<u>2023</u>	<u>2022</u>
Net income (per-GAAP)	\$ 82,020	\$ 80,155	\$ 153,170	\$ 152,846
Plus:				
Interest expense (income), net	(35)	729	325	1,017
Income tax provision	17,224	18,461	33,840	35,107
Depreciation and amortization	34,243	31,301	67,896	59,895
EBITDA (non-GAAP)	<u>\$ 133,452</u>	<u>\$ 130,646</u>	<u>\$ 255,231</u>	<u>\$ 248,865</u>

DIODES INCORPORATED AND SUBSIDIARIES
CONSOLIDATED CONDENSED BALANCE SHEETS
(in thousands)

	June 30, 2023 <i>(unaudited)</i>	December 31, 2022 <i>(audited)</i>
Assets		
Current assets:		
Cash and cash equivalents	\$ 321,616	\$ 336,732
Restricted Cash	3,120	4,367
Short-term investments	9,042	7,059
Accounts receivable, net of allowances of \$5,634 and \$5,852 at June 30, 2023 and December 31, 2022, respectively	393,132	369,233
Inventories	325,733	360,281
Prepaid expenses and other	107,746	83,999
Total current assets	1,160,389	1,161,671
Property, plant and equipment, net	748,115	736,730
Deferred income tax	35,354	35,308
Goodwill	146,138	144,757
Intangible assets, net	71,496	79,137
Other long-term assets	179,579	130,709
Total assets	\$ 2,341,071	\$ 2,288,312
Liabilities		
Current liabilities:		
Line of credit	\$ 33,729	\$ 36,280
Accounts payable	152,192	160,442
Accrued liabilities	198,882	214,433
Income tax payable	27,004	19,682
Current portion of long-term debt	1,149	1,693
Total current liabilities	412,956	432,530
Long-term debt, net of current portion	54,575	147,470
Deferred tax liabilities	13,550	12,903
Unrecognized tax benefits	31,594	31,594
Other long-term liabilities	97,818	80,896
Total liabilities	610,493	705,393
Commitments and contingencies		
Stockholders' equity		
Preferred stock - par value \$1.00 per share; 1,000,000 shares authorized; no shares issued or outstanding	-	-
Common stock - par value \$0.66 2/3 per share; 70,000,000 shares authorized; 45,748,940 and 45,469,722, issued and outstanding at June 30, 2023 and December 31, 2022, respectively	36,690	36,503
Additional paid-in capital	501,302	494,773
Retained earnings	1,601,262	1,448,092
Treasury stock, at cost, 9,283,481 shares held at June 30, 2023 and 9,281,581 shares held at December 31, 2022	(337,670)	(337,490)
Accumulated other comprehensive loss	(139,104)	(128,233)
Total stockholders' equity	1,662,480	1,513,645
Noncontrolling interest	68,098	69,274
Total equity	1,730,578	1,582,919
Total liabilities and stockholders' equity	\$ 2,341,071	\$ 2,288,312

**Second Quarter 2023
Financial Results
Diodes Incorporated (DIOD)**

August 8, 2023



www.diodes.com

Safe Harbor Statement Under the Private Securities Litigation Reform Act of 1995: Any statements set forth above that are not historical facts are forward-looking statements that involve risks and uncertainties that could cause actual results to differ materially from those in the forward-looking statements. Such statements include statements containing forward-looking words such as “expect,” “anticipate,” “aim,” “estimate,” and variations thereof, including without limitation statements, whether direct or implied, regarding expectations of that for the third quarter of 2023, we expect revenue to be approximately \$425 million plus or minus 3 percent; we expect GAAP gross margin to be 40.0 percent, plus or minus 1 percent; non-GAAP operating expenses, which are GAAP operating expenses adjusted for amortization of acquisition-related intangible assets, are expected to be approximately 23.0 percent of revenue, plus or minus 1 percent; we expect non-GAAP net interest expense to be approximately \$1.0 million; we expect our income tax rate to be 20.0 percent, plus or minus 3 percent; shares used to calculate diluted EPS for the third quarter are anticipated to be approximately 46.7 million. Potential risks and uncertainties include, but are not limited to, such factors as: the risk that the COVID-19 pandemic may continue and have a material adverse effect on customer demand and staffing of our production, sales and administration facilities; the risk that such expectations may not be met; the risk that the expected benefits of acquisitions may not be realized or that integration of acquired businesses may not continue as rapidly as we anticipate; the risk that the cost, expense, and diversion of management attention associated with the LSC acquisition may be greater than we currently expect; the risk that we may not be able to maintain our current growth strategy or continue to maintain our current performance, costs, and loadings in our manufacturing facilities; the risk that we may not be able to increase our automotive, industrial, or other revenue and market share; risks of domestic and foreign operations, including excessive operating costs, labor shortages, higher tax rates, and our joint venture prospects; the risks of cyclical downturns in the semiconductor industry and of changes in end-market demand or product mix that may affect gross margin or render inventory obsolete; the risk of unfavorable currency exchange rates; the risk that our future outlook or guidance may be incorrect; the risks of global economic weakness or instability in global financial markets; the risks of trade restrictions, tariffs, or embargoes; the risk that the coronavirus outbreak or other similar epidemics may harm our domestic or international business operations to a greater extent than we currently anticipate; the risk of breaches of our information technology systems; and other information, including the “Risk Factors” detailed from time to time in Diodes’ filings with the United States Securities and Exchange Commission.

This presentation also contains non-GAAP measures. See the Company’s press release on August 8, 2023 titled, “Diodes Incorporated Reports Second Quarter Fiscal 2023 Financial Results” for detailed information related to the Company’s non-GAAP measures and a reconciliation of GAAP net income to non-GAAP net income.



DISCRETE
ANALOG
LOGIC
MIXED-SIGNAL

Diodes delivers high-quality (analog, discrete, and mixed signal) semiconductor products to the world's leading companies in the automotive, industrial, computing, consumer electronics, and communications markets



Vision: Profitability Growth to Maximize Shareholder Value

Our Core Values: Integrity, Commitment, Innovation



DISCRETE
ANALOG
LOGIC
MIXED-SIGNAL

- Goal 1: \$1B Market Cap ✓
- Goal 2: \$1B Annual Revenue ✓
- Goal 3: \$1B Gross Profit
- Goal 4: \$1B Profit Before Tax

2025 Target:
\$1B Gross profit

Gross Margin: 40%
Revenue: \$2.5B

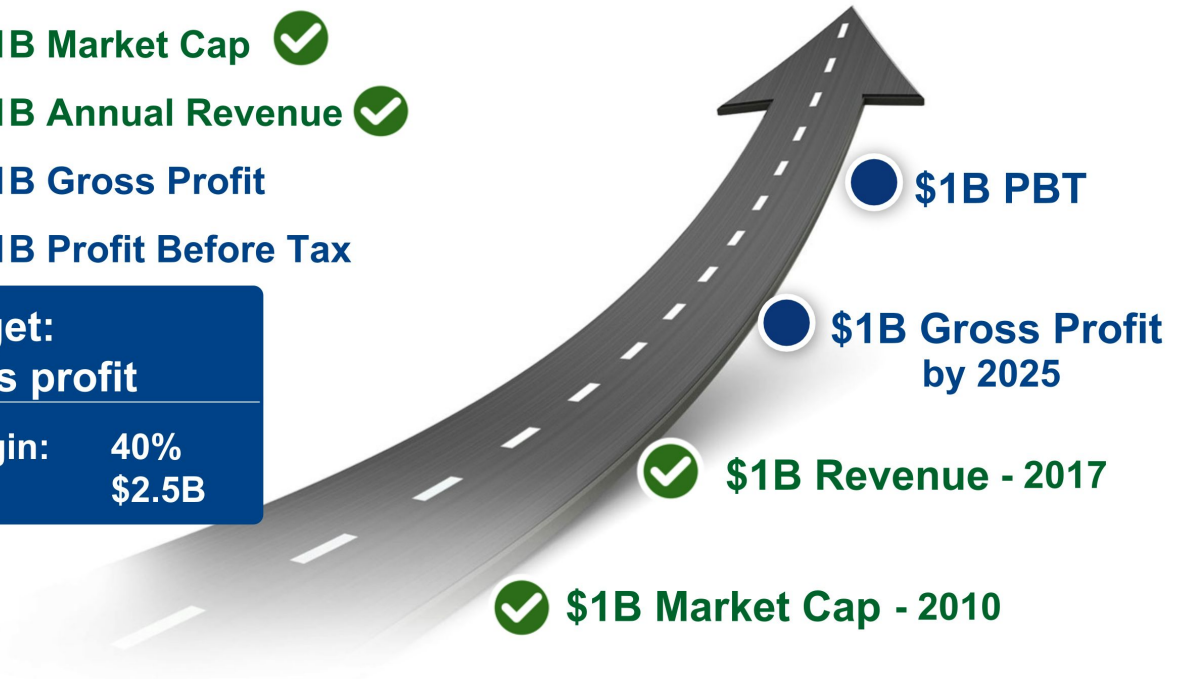

DISCRETE
ANALOG
LOGIC
MIXED-SIGNAL

**~40% of
revenue**
(48% for Q2 2023)

Automotive

- Connected driving, comfort/style/safety, electrification/powertrain

Industrial

- Embedded systems and precision controls, and IIoT

Consumer

- IoT: wearables, home automation, smart infrastructure

Communications

- Smart phones, 5G networks, advanced protocols, and charging solutions

Computing

- Cloud computing: server, storage, data centers

**~60% of
revenue**
(52% for Q2 2023)



DISCRETE
ANALOG
LOGIC
MIXED-SIGNAL

Automotive and Industrial are Driving Growth

- **Automotive** – 31% CAGR (2013 – 2022)
 - Focused on connected driving, comfort, style, safety, and electrification
 - Released 110 new automotive-compliant products (including SiC MOSFETs) in 2Q'23
 - Increased dollar content per car to \$140
- **Industrial** – 15% CAGR (2013 – 2022)
 - Focused on embedded systems, networked systems, automation, motor controls, sensors, power management, and IIoT
 - Building momentum for SiC Schottky diodes and MOSFETs
 - Expanding content in security, medical, green energy generation and energy storage systems



DISCRETE
ANALOG
LOGIC
MIXED-SIGNAL

Revenue \$467.2M Flat Q-Q	GAAP Gross Profit \$195.4M ↑ + 0.5 % Q-Q	GAAP Gross Margin 41.8% ↑ + 20 bps Q-Q	Non-GAAP EPS \$1.59 Flat Q-Q
Non-GAAP Net Income \$73.3M Flat Q-Q	EBITDA \$133.5M 28.6% of Revenue	Cash Flow from Ops \$92.6M 19.8% of Revenue	Strong Balance Sheet \$334M/\$89M Cash/Debt



DISCRETE
ANALOG
LOGIC
MIXED-SIGNAL



Gross margin reached record 41.8% in 2Q'23, an increase of 60bps from 2Q'22



2Q'23 represented sixth consecutive quarter of above 40% (our target model) gross margin



Automotive revenue reached record 19% of product revenue



Achieved 29% of product revenue in the Industrial market



Automotive and Industrial totaled 48% of product revenue, exceeding 2025 target of 40%



DISCRETE
ANALOG
LOGIC
MIXED-SIGNAL

Profitability Growth

Track record of Continued Outperformance

Annual Revenue (\$ in millions)

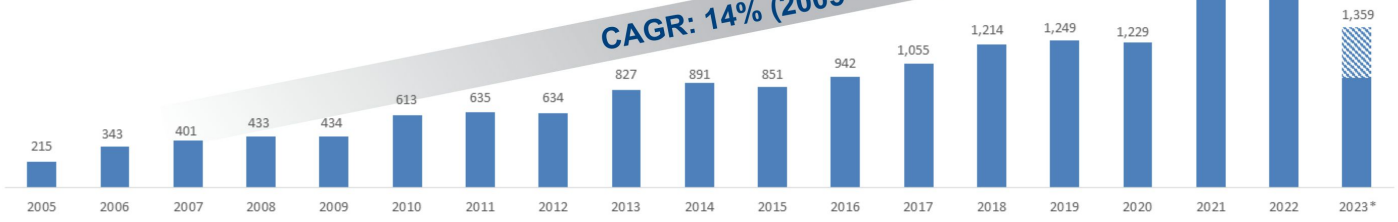

Gross Profit (\$ in millions)

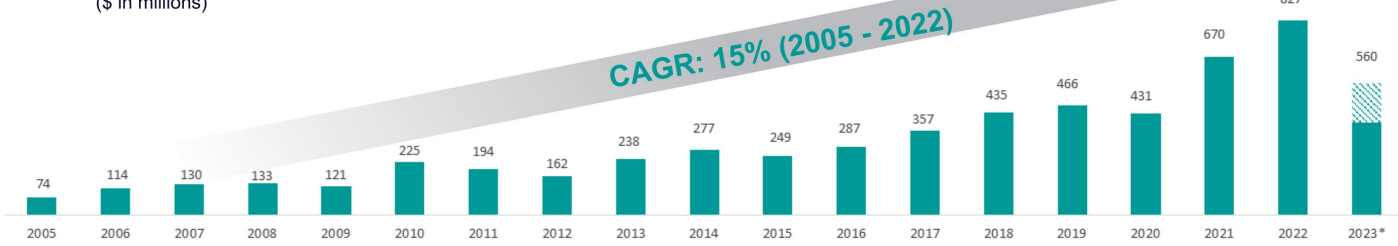

DISCRETE
ANALOG
LOGIC
MIXED-SIGNAL

* Revenue/Gross Profit for 2023 are based on first half results and Q3 guidance provided on August 8, 2023

Quarterly Revenue (\$ Millions)

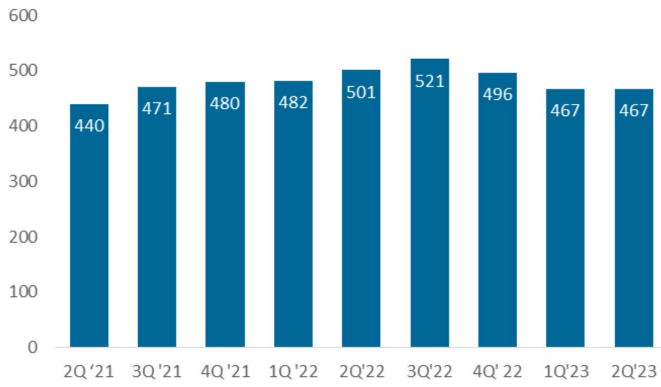

Quarterly Gross Profit (\$ Millions)

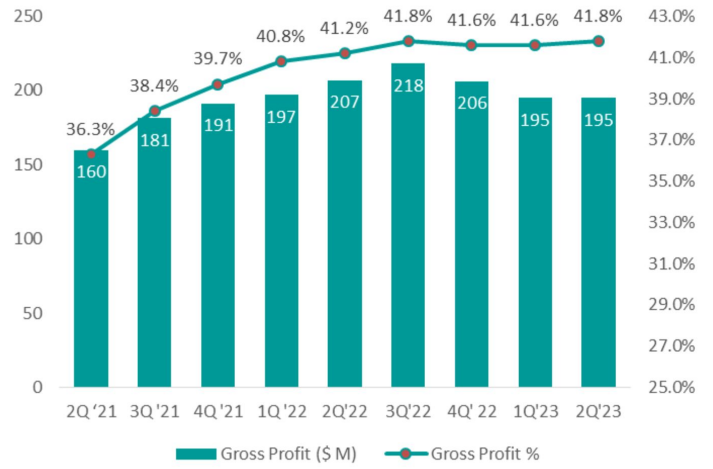

DISCRETE
ANALOG
LOGIC
MIXED-SIGNAL

By Channel

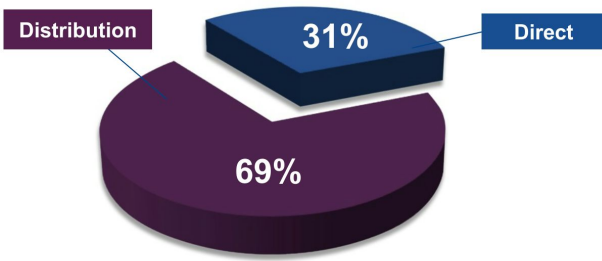

By Region

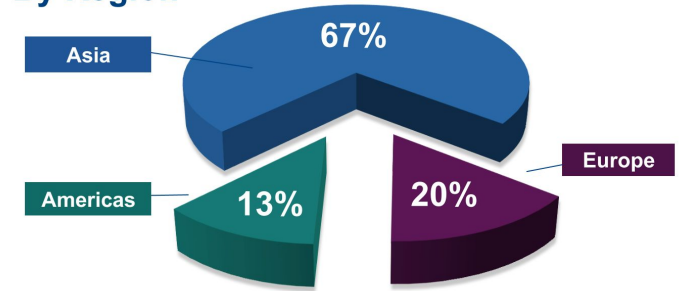

By End Market

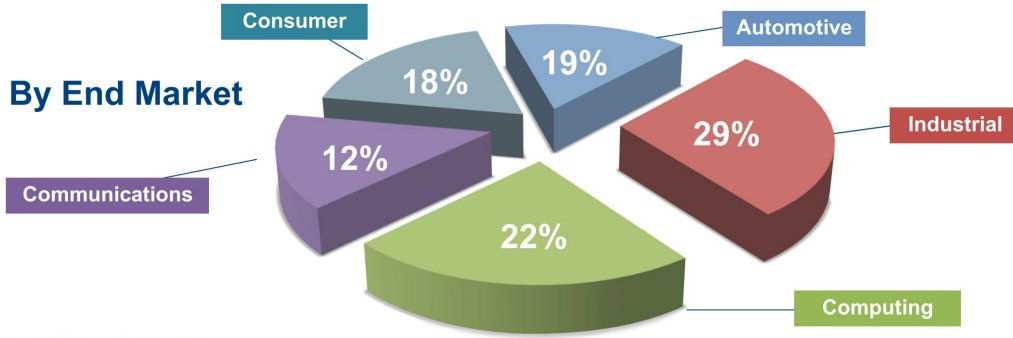

DISCRETE
ANALOG
LOGIC
MIXED-SIGNAL

Income Statement – Second Quarter 2023

(\$ in millions, except per share amounts)	2Q22	1Q23	2Q23
Net sales	501.0	467.2	467.2
Gross profit (GAAP)	206.5	194.5	195.4
Gross profit margin % (GAAP)	41.2%	41.6%	41.8%
Net income (GAAP)	80.2	71.2	82
Net income (non-GAAP)	86.9	73.4	73.3
Diluted EPS (non-GAAP)	1.90	1.59	1.59
Cash flow from operations	85.0	99.8	92.6
EBITDA (non-GAAP)	130.4	121.8	133.5



DISCRETE
ANALOG
LOGIC
MIXED-SIGNAL

(\$ in millions)	Dec 31, 2021	Dec 31, 2022	June 30, 2023
Cash*	373	348	334
Inventory	349	360	326
Current Assets	1,188	1,162	1,160
Total Assets	2,194	2,288	2,341
Total Debt	301	185	89
Total Liabilities	892	705	610
Total Equity	1,303	1,583	1,731

* Cash, Restricted Cash and Short-term investments



DISCRETE
ANALOG
LOGIC
MIXED-SIGNAL

- Revenue to be ~\$425 million, +/- 3.0%
- GAAP gross margin of 40%, +/- 1%
- Non-GAAP operating expenses 23.0% of revenue, +/- 1%, which are GAAP operating expenses adjusted for amortization of acquisition-related intangible assets
- Net Interest expense of ~\$1.0 million
- Income tax rate to be 20%, +/- 3%
- Shares used to calculate diluted EPS approximately 46.7 million
- Amortization of acquisitions-related intangible assets of \$3.1 million, after tax, for previous acquisitions is not included in these non-GAAP estimates



DISCRETE
ANALOG
LOGIC
MIXED-SIGNAL

**Guidance as provided on August 8 2023*

- **Vision: Expand shareholder value**
- **Mission: Profitability growth to drive 20%+ operating profit**
- **Next Strategic Goal: \$1B gross profit**
- **Tactics:**
 - Total system solutions sales approach and content expansion driving growth
 - Increased focus on high-margin Automotive, Industrial, analog, and power discrete products
 - Investment for technology leadership in target products, fab processes, and advanced packaging



DISCRETE
ANALOG
LOGIC
MIXED-SIGNAL



DIODES
INCORPORATED

Thank you



www.diodes.com

Reconciliation of Net Income to Adjusted Net Income

For the three months ended June 30, 2023:

(in thousands, except per share data)

(unaudited)

	Operating Expenses	Other (Income) Expense	Income Tax Provision	Net Income
Per-GAAP				\$ 82,020
Diluted earnings per share (per-GAAP)				\$ 1.77
Adjustments to reconcile net income to non-GAAP net income:				
Amortization of acquisition-related intangible assets	3,817		(726)	3,091
Officer retirement	(57)		11	(46)
Non-cash market-to-market investment value adjustments		(12,172)	440	(11,732)
Non-GAAP				\$ 73,333
Diluted shares used in computing earnings per share				46,243
Non-GAAP diluted earnings per share				\$ 1.59

Note: Included in GAAP and non-GAAP net income was approximately \$6.0 million, net of tax, non-cash share-based compensation expense. Excluding share-based compensation expense, both GAAP and non-GAAP diluted earnings per share would have increased by \$0.13 per share.



DISCRETE
ANALOG
LOGIC
MIXED-SIGNAL

GAAP to Non-GAAP Reconciliation

For the three months ended June 30, 2022:

(in thousands, except per share data)

(unaudited)

	Operating Expenses	Other Income (Expense)	Income Tax Provision	Net Income
Per-GAAP				<u>\$ 80,155</u>
Diluted earnings per share (Per-GAAP)				<u>1.75</u>
Adjustments to reconcile net income to non-GAAP net income:				
Amortization of acquisition-related intangible assets	3,980		(729)	3,251
Acquisition-related costs	204		(44)	160
Insurance Recovery for Manufacturing Facility	(3,594)		719	(2,875)
Non-cash market-to-market investment value adjustments		7,764	(1,553)	6,211
Non-GAAP				<u>\$ 86,902</u>
Diluted shares used in computing earnings per share				<u>45,841</u>
Non-GAAP diluted earnings per share				<u>\$ 1.90</u>

Note: Included in GAAP and non-GAAP adjusted net income was approximately \$6.6 million, net of tax, non-cash share-based compensation expense. Excluding share-based compensation expense, both GAAP and non-GAAP adjusted diluted earnings per share would have increased by \$0.14 per share.



DISCRETE
ANALOG
LOGIC
MIXED-SIGNAL

Investor Relations

Diodes Incorporated (DIOD)

Plano, TX, USA

Aug 8, 2023



www.diodes.com

Safe Harbor Statement Under the Private Securities Litigation Reform Act of 1995: Any statements set forth above that are not historical facts are forward-looking statements that involve risks and uncertainties that could cause actual results to differ materially from those in the forward-looking statements. Such statements include statements containing forward-looking words such as “expect,” “anticipate,” “aim,” “estimate,” and variations thereof, including without limitation statements, whether direct or implied, regarding expectations of that for the third quarter of 2023, we expect revenue to be approximately \$425 million plus or minus 3 percent; we expect GAAP gross margin to be 40.0 percent, plus or minus 1 percent; non-GAAP operating expenses, which are GAAP operating expenses adjusted for amortization of acquisition-related intangible assets, are expected to be approximately 23.0 percent of revenue, plus or minus 1 percent; we expect non-GAAP net interest expense to be approximately \$1.0 million; we expect our income tax rate to be 20.0 percent, plus or minus 3 percent; shares used to calculate diluted EPS for the third quarter are anticipated to be approximately 46.7 million. Potential risks and uncertainties include, but are not limited to, such factors as: the risk that the COVID-19 pandemic may continue and have a material adverse effect on customer demand and staffing of our production, sales and administration facilities; the risk that such expectations may not be met; the risk that the expected benefits of acquisitions may not be realized or that integration of acquired businesses may not continue as rapidly as we anticipate; the risk that the cost, expense, and diversion of management attention associated with the LSC acquisition may be greater than we currently expect; the risk that we may not be able to maintain our current growth strategy or continue to maintain our current performance, costs, and loadings in our manufacturing facilities; the risk that we may not be able to increase our automotive, industrial, or other revenue and market share; risks of domestic and foreign operations, including excessive operating costs, labor shortages, higher tax rates, and our joint venture prospects; the risks of cyclical downturns in the semiconductor industry and of changes in end-market demand or product mix that may affect gross margin or render inventory obsolete; the risk of unfavorable currency exchange rates; the risk that our future outlook or guidance may be incorrect; the risks of global economic weakness or instability in global financial markets; the risks of trade restrictions, tariffs, or embargoes; the risk that the coronavirus outbreak or other similar epidemics may harm our domestic or international business operations to a greater extent than we currently anticipate; the risk of breaches of our information technology systems; and other information, including the “Risk Factors” detailed from time to time in Diodes’ filings with the United States Securities and Exchange Commission.

This presentation also contains non-GAAP measures. See the Company’s press release on August 8, 2023 titled, “Diodes Incorporated Reports Second Quarter Fiscal 2023 Financial Results” for detailed information related to the Company’s non-GAAP measures and a reconciliation of GAAP net income to non-GAAP net income.



DISCRETE
ANALOG
LOGIC
MIXED-SIGNAL

Dr. Keh-Shew Lu

Chairman, President and CEO

Experience:

- President & CEO, Diodes Incorporated Since 2005
- Texas Instruments 27 years
 - Senior Vice President of TI Worldwide Analog and Logic
 - President of Texas Instruments – Asia

Education:

- Honorary Doctorate in Engineering
National Cheng Kung University
- Doctorate and Master's Degree in Electrical Engineering
Texas Tech University
- Bachelor's Degree in Engineering
National Cheng Kung University – Taiwan



DISCRETE
ANALOG
LOGIC
MIXED-SIGNAL

Gurmeet Dhaliwal

Company spokesperson
Director, Investor Relations

Experience:

- Head of Corporate Marketing, Diodes Incorporated, Milpitas, CA
- Head of Corporate Marketing, Pericom, Milpitas, CA
- Vice President, Marketing, CA Technologies (Broadcom), Redwood City, CA
- Director, Global Marketing Strategy, EMC, Pleasanton, CA
- Director, Marketing, Zarlink Semiconductor (Microchip), San Jose, CA
- Marketing Management positions at Cisco and National Semiconductor, CA

Education:

- MBA, Marketing/Entrepreneurship, Saint Mary's College of California
- BS in Electrical and Computer Engineering, UC Santa Barbara



DISCRETE
ANALOG
LOGIC
MIXED-SIGNAL

Diodes delivers high-quality (analog, discrete, and mixed signal) semiconductor products to the world's leading companies in the automotive, industrial, computing, consumer electronics, and communications markets



Vision: Profitability Growth to Maximize Shareholder Value

Our Core Values: Integrity, Commitment, Innovation



DISCRETE
ANALOG
LOGIC
MIXED-SIGNAL

Global Operations and World-class Manufacturing & Packaging

- NASDAQ: DIOD; Founded in 1959
- Headquartered in Plano, TX; 32 locations globally
- Manufacturing in US, UK, Germany, China, and Taiwan
- ISO 9001:2015 Certified / IATF 16949:2016 Certified
- ISO 14001:2015 Certified
- Key acquisitions:
 - onsemi SPFAB – June 2022
 - Lite-On Semiconductor – Nov. 2020
 - TI Greenock fab (GFAB) - April 2019
 - Pericom Semiconductor – Nov. 2015
 - BCD Semiconductor - March 2013
 - Power Analog Microelectronics (PAM) - Oct. 2012
 - Zetex - June 2008
 - Advanced Power Devices - Nov. 2006
 - Anachip Corporation Taiwan - Jan. 2006
- 31 consecutive years of profitability



DISCRETE
ANALOG
LOGIC
MIXED-SIGNAL



DISCRETE
ANALOG
LOGIC
MIXED-SIGNAL

We view sustainability as a competitive advantage and have adopted a sustainability-oriented approach to assess and address related risks that may influence our operational activities, business results, and financial performance.



- Key focus areas regularly reviewed by our Board of Directors
- Instituted a cross-functional Sustainability Steering Team to address the sustainability related risks and opportunities
- The Sustainability Steering Team provides periodic updates to the Board of Directors



DISCRETE
ANALOG
LOGIC
MIXED-SIGNAL

Please refer to [Governance and Oversight](#) for additional details

- Goal 1: \$1B Market Cap ✓
- Goal 2: \$1B Annual Revenue ✓
- Goal 3: \$1B Gross Profit
- Goal 4: \$1B Profit Before Tax

2025 Target:
\$1B Gross profit

Gross Margin:	40%
Revenue:	\$2.5B

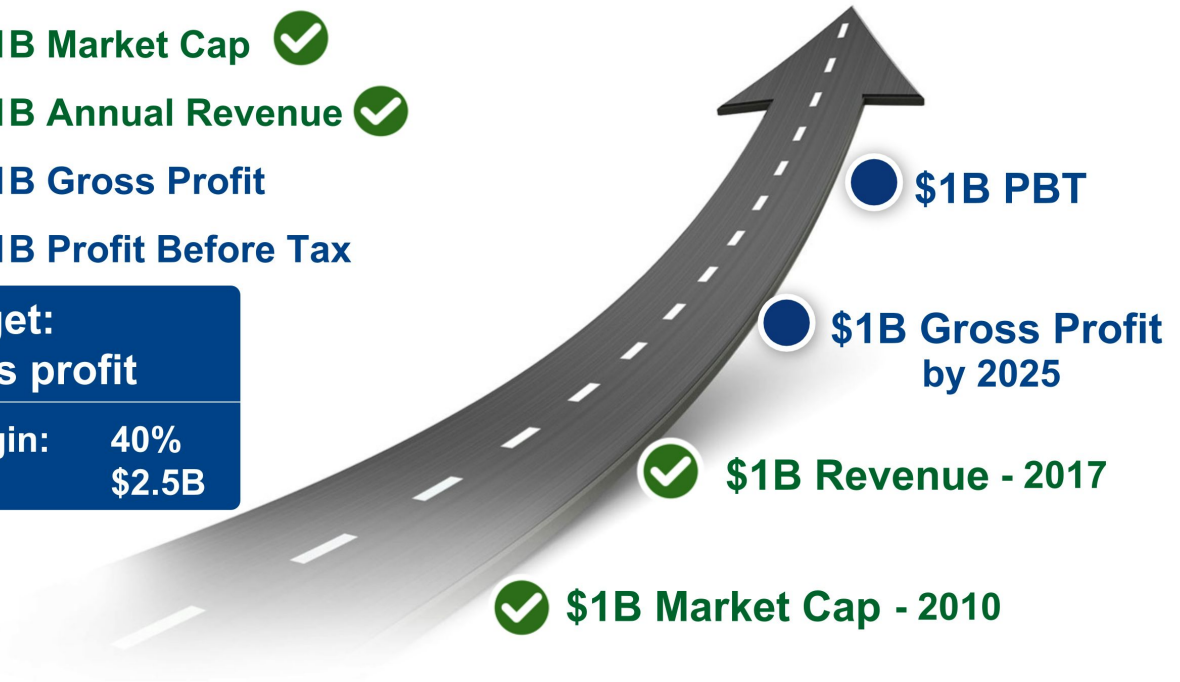

DISCRETE
ANALOG
LOGIC
MIXED-SIGNAL

Profitability Growth

Track record of Continued Outperformance

Annual Revenue (\$ in millions)

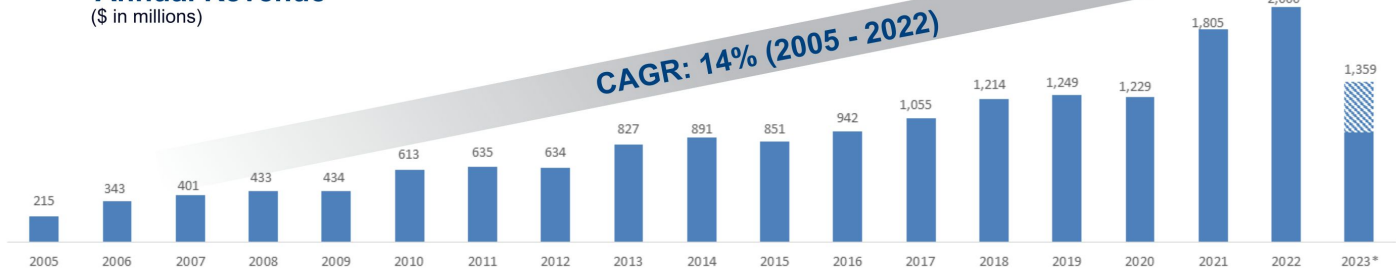

Gross Profit (\$ in millions)

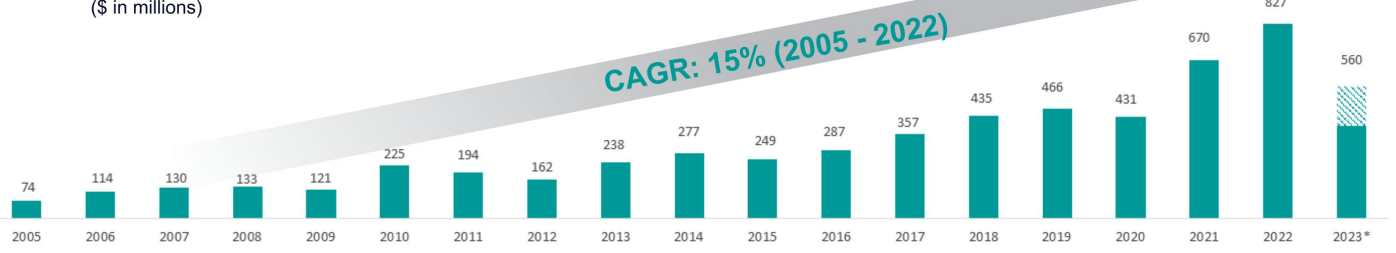

DISCRETE
ANALOG
LOGIC
MIXED-SIGNAL

* Revenue/Gross Profit for 2023 are based on first half results and Q3 guidance provided on August 8, 2023

~40% of revenue
(48% for Q2 2023)

Automotive

- Connected driving, comfort/style/safety, electrification/powertrain

Industrial

- Embedded systems and precision controls, and IIoT

Consumer

- IoT: wearables, home automation, smart infrastructure

Communications

- Smart phones, 5G networks, advanced protocols, and charging solutions

Computing

- Cloud computing: server, storage, data centers

~60% of revenue
(52% for Q2 2023)



DISCRETE
ANALOG
LOGIC
MIXED-SIGNAL

Automotive and Industrial are Driving Growth

- **Automotive** – 31% CAGR (2013 – 2022)
 - Focused on connected driving, comfort, style, safety, and electrification
 - Released 110 new automotive-compliant products (including SiC MOSFETs) in 2Q'23
 - Increased dollar content per car to \$140
- **Industrial** – 15% CAGR (2013 – 2022)
 - Focused on embedded systems, networked systems, automation, motor controls, sensors, power management, and IIoT
 - Building momentum for SiC Schottky diodes and MOSFETs
 - Expanding content in security, medical, green energy generation and energy storage systems



DISCRETE
ANALOG
LOGIC
MIXED-SIGNAL

Capability up to:
 32Gbps PCIe® 5.0
 24Gbps SAS-4
 20Gbps USB 3.2/USB4
 20Gbps Thunderbolt™ 4
 20Gbps DisplayPort™ 2.1
 12Gbps HDMI™ 2.1 10Gbps Ethernet
 6Gbps SATA 3.0
 2.5Gbps MIPI D-PHY 1.2

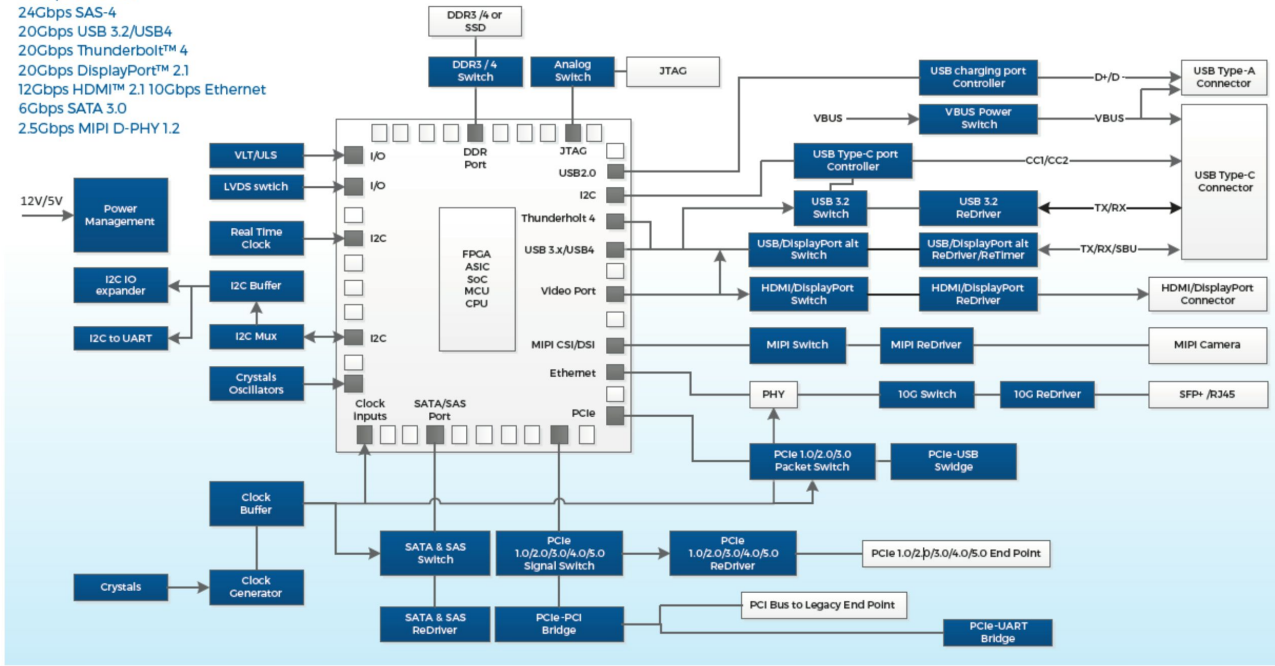

DISCRETE
 ANALOG
 LOGIC
 MIXED-SIGNAL

Example: Embedded System Applications

Focus Applications:

Connected Driving

- **ADAS** (Advanced Driver Assistance Systems)
- **Telematics**
- **Infotainment Systems**
- **Smart cockpit, Wireless charger**

Comfort, Style, and Safety

- **Lighting**
 - Migration to LED and intelligent illumination
- **BLDC motor / fan control**
 - Migration from Brushed to Brushless DC Motors

Electrification/Powertrain

- **Conventional Powertrain → Hybrid → Electrification**
- **Power Module Inverter for EV motor**
- **Battery management**
 - Move to 48V battery

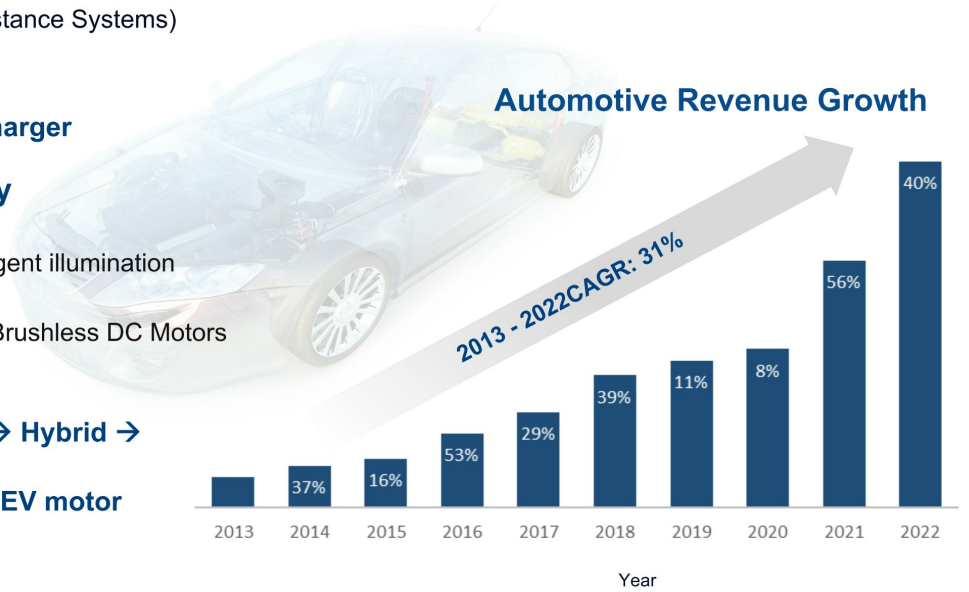

DISCRETE
ANALOG
LOGIC
MIXED-SIGNAL

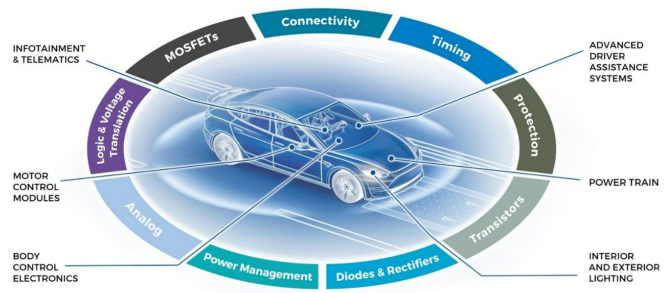
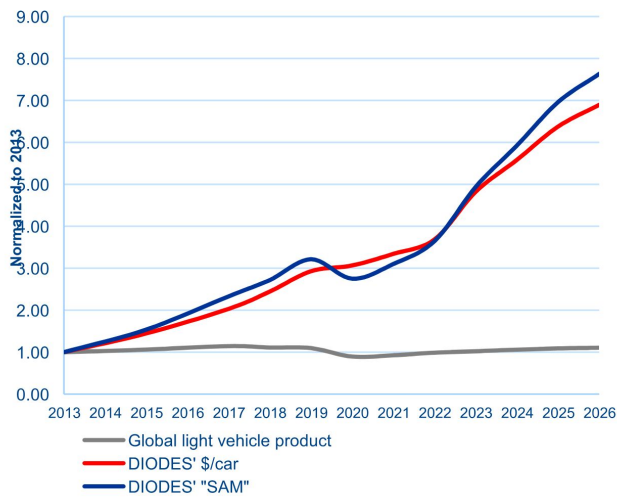

Automotive Potential Revenue	\$ / Car
Automotive Motor Control	\$45.50
Connected Driving (Infotainment, Telematics & ADAS)	\$60.50
Powertrain, Electrification & Body Control Electronics	\$19.70
Lighting – Moving to LED	\$14.30
Total	\$140.00



DISCRETE
ANALOG
LOGIC
MIXED-SIGNAL

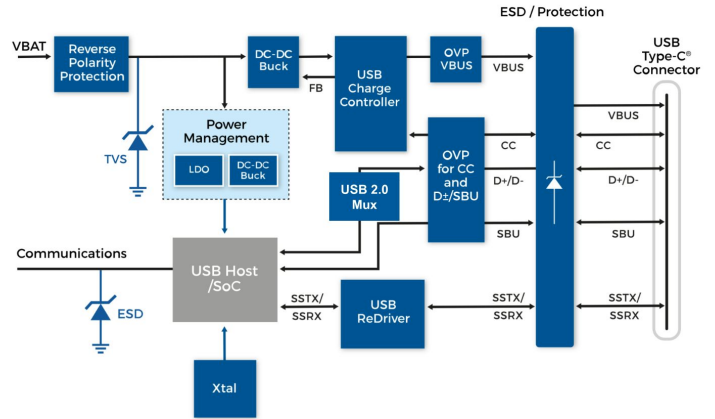

Diodes' Key Products	\$ / per car
Power Management	\$5.30
MOS/BJT	\$1.00
Diodes and Rectifiers	\$0.50
Timing and Connectivity	\$2.80
Total	\$9.60

- USB charging is a high growth application with approximately 2 to 8 ports per vehicle
- Diodes provides a system solution for USB charging including Port Controller, USB Muxes, Signal Switches, ReDrivers, Xtals, Power Management, and Protection.
- Automotive Compliant* product portfolio expansion is expanding the SAM further



DISCRETE
ANALOG
LOGIC
MIXED-SIGNAL

* AEC qualified, manufactured in IATF 16949 certified sites supporting PPAP documents (if applicable).



Diodes' Key Products	\$ / Box
Analog	>\$1.20
Power Management	>\$0.70
MOS/BJT	>\$3.50
Diodes and Rectifiers	>\$5.00
Timing and Connectivity	\$14.00
Total	\$24.40

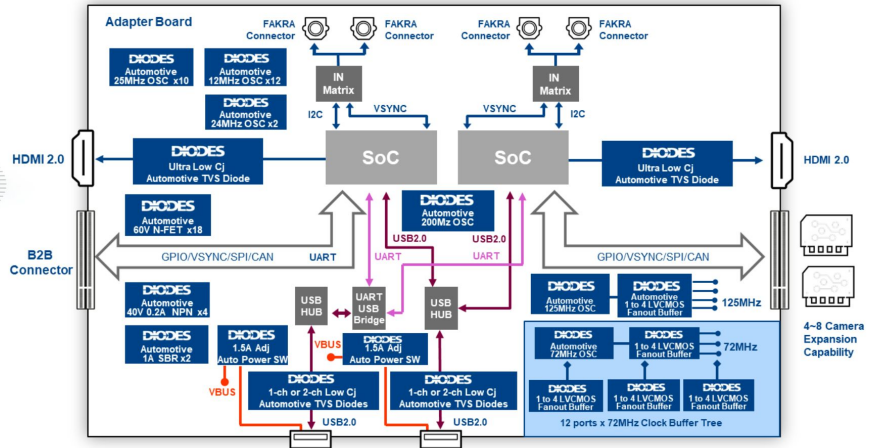

- **Advanced Clock Gen, Clock Buffer, Crystal Oscillator, USB Power Switch, and Protection solutions for mission-critical need**
- **Automotive Compliant* Products**



DISCRETE
ANALOG
LOGIC
MIXED-SIGNAL

* AEC qualified, manufactured in IATF 16949 certified sites supporting PPAP documents (if applicable).

- Increasing IC content in embedded systems
- Switching and signal path for networked systems and automation
- Signal conditioning and timing for precision controls
- Industrial / motor controls, sensors, and power management for smart meters
- Green power, Energy storage



Industrial Revenue Growth

Net Sales



DISCRETE
ANALOG
LOGIC
MIXED-SIGNAL

- **M2M – Dominated by short range technology**
 - 73% are short range, mostly Wi-Fi
- **2030: connections @ 29,400 million**

M2M – By Application

- IoT and M2M Modems
- POS, Routers, Edge Server
- On-Premise Edge Gateway
- AGV (Automated Guided Vehicle)
- AMR (Autonomous Mobile Robots)
- UAV (Unmanned Aerial Vehicle)

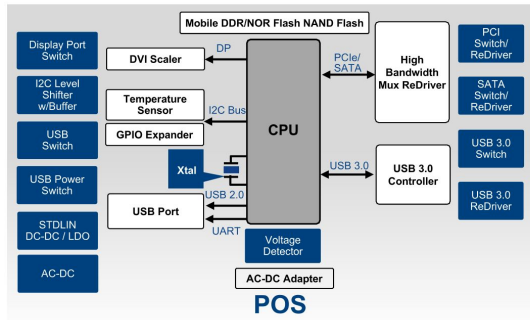
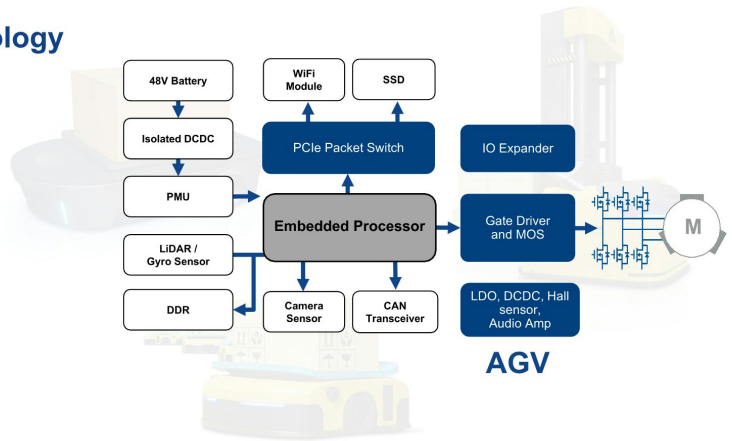

Growth Opportunities:

- Power, Sensor, DC-DC
- Gate Driver, BJT, MOSFET
- XTAL and clock
- Packet switch, ReDriver, IO Expander, MIPI, and USB charging

Diodes' Key Products	\$ / AGV
Discrete	\$3.50
Analog & Power Mgmt.	\$2.20
Timing and Connectivity	\$18.00
Total	\$23.70

- ReDriver support for PCIe or USB connectivity
- Wide range of signal protocols: PCIe, CXL, SAS, SATA, USB
- MUX products for high capacity solid state storage
- Crystal oscillators for increasing clocking speeds
- LDOs, DCDC, SBR, and TVS for power management and protection



DISCRETE
ANALOG
LOGIC
MIXED-SIGNAL

Server Platform Solution

- Almost all of Server vendors are Diodes' existing customers
- Diodes' products are well positioned in this segment
 - Connectivity, Signal Integrity, Timing, Standard Linear, Power Management, Power Switch, Level shifter, Protection or HV MOSFET / SBR devices

Diodes' Key Products	\$ / Server
Analog	3.80
Discrete	3.60
Timing and Connectivity	33.00
Total	\$40.40

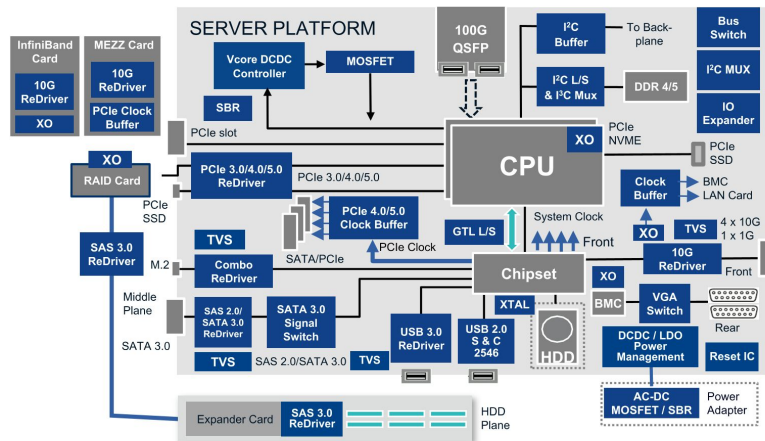

WW server market is expected to grow during 2023 – 2027 with CAGR of 7.7%



DISCRETE
ANALOG
LOGIC
MIXED-SIGNAL



Diodes' Key Products	\$ / Box
Analog	>\$0.20
Power Management	>\$1.30
MOS/BJT	>\$10.00
Diodes and Rectifiers	>\$5.00
Timing and Connectivity	\$3.50
Total	\$20.00



DISCRETE
ANALOG
LOGIC
MIXED-SIGNAL

Smart Home

- Safety and Security
- Climate Control
- Consumer Electronics
- Lighting control

Growth Opportunities

- Power
- LED driver
- Xtal and clock
- Packet switch



Diodes' Key Products	\$ / Box
Analog	\$0.55 ~ \$0.80
Power Management	\$1.80
MOS/BJT	\$1.10
Diodes and Rectifiers	\$0.50
Timing and Connectivity	\$3.50
Total	\$7.70

Smart Home Gateway

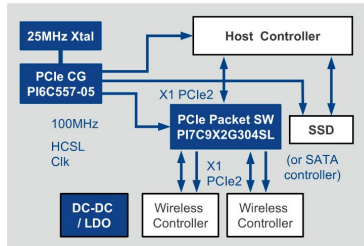

Smart Lighting

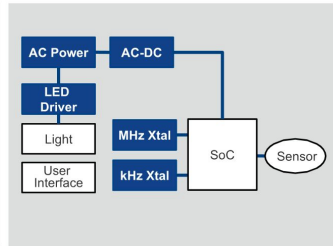

Smart Speaker

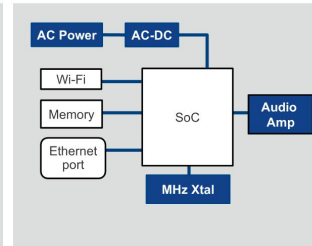

Digital Assistant

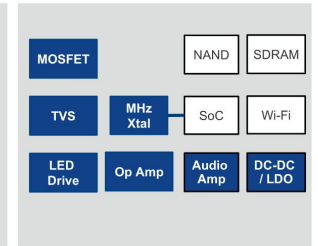

DISCRETE
ANALOG
LOGIC
MIXED-SIGNAL

Focus Applications:

Cloud Computing

- AI / Data Center Server

Gateway

- Internet Gateway
- Fiber network

Core Network, Cell Stations

- Small Cells
- Base Station
- Edge Computing Server
- Smart antenna
- Fiber network

End Products

- Portables: Smartphone, Tablet
- Smart Car
- Consumer: VR/AR, Drone, IoT
- Telecom: 5G CPEs
- Embedded/Industrial



DISCRETE
ANALOG
LOGIC
MIXED-SIGNAL

- Advanced Solution in Signal Integrity, Signal/Bus/Power Switches and IO Expanders for diversified networking applications
- Global Logistics provide cost-competitive solution with industry standard pin-outs and flexible package options

Diodes' Key Products	\$ / Box
Analog	>\$0.60
Power Management	\$0.90
MOS/BJT	>\$0.50
Timing and Connectivity	\$11.00
Total	\$13.00

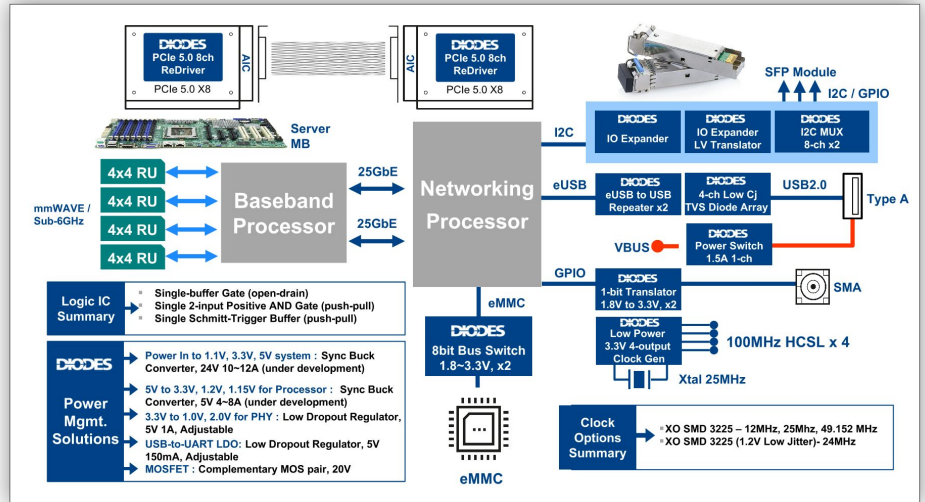

DISCRETE
ANALOG
LOGIC
MIXED-SIGNAL

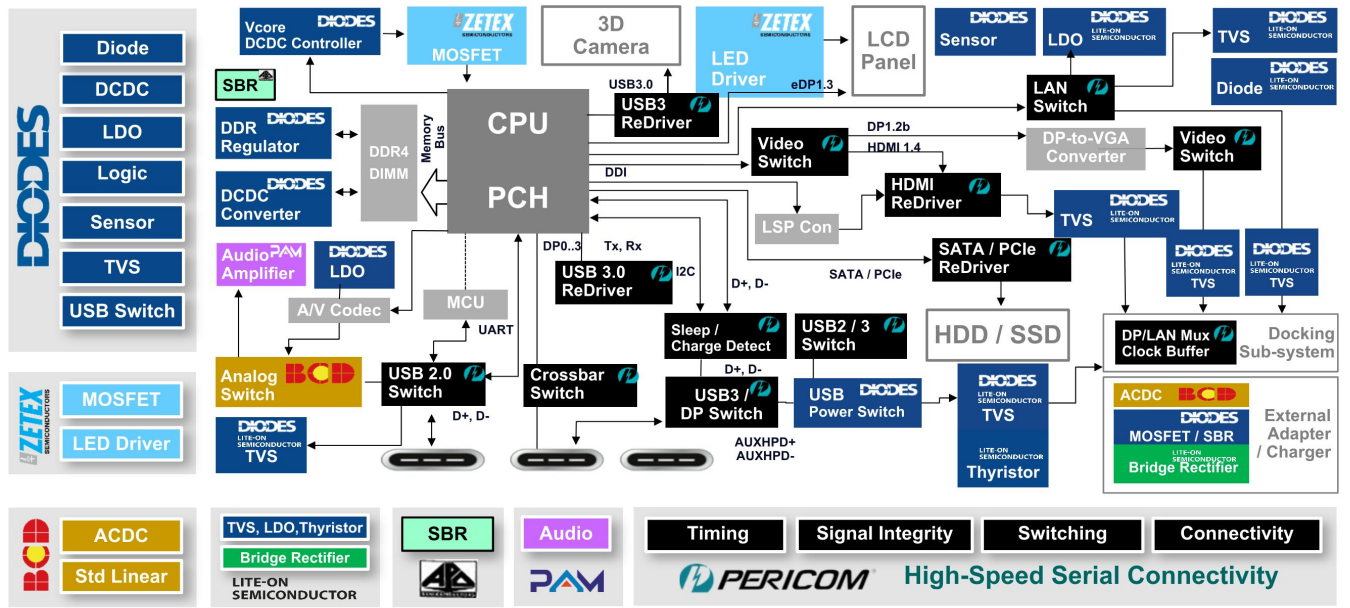

DISCRETE
ANALOG
LOGIC
MIXED-SIGNAL

Products



- 32 Gbps ReDrivers and Switches
- Automotive Packet Switch for Telematics / ADAS
- Complete USB Type-C Solution
- Low jitter timing solution for cloud computing
- Ultra low power and low noise LDOs for IoT
- Low Cj TVS for signal integrity
- Lowest RDS(ON) LDMOS for battery efficiency
- SiC Merged PiN Schottky Diodes and SiC MOSFET for industrial and automotive applications

Wafer Fab

- High performance 8" MOSFET trench technology
- Advanced Epi bipolar transistor processes
- Proprietary rectifier technology
- Rugged automotive grade NMOS and PMOS

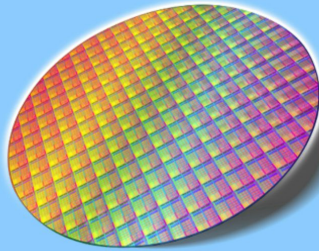

Assembly/Test

- Compact QFN and DFN
- Power density PowerDI
- Chip scale packaging and plating capability
- Extensive multi-chip package technology

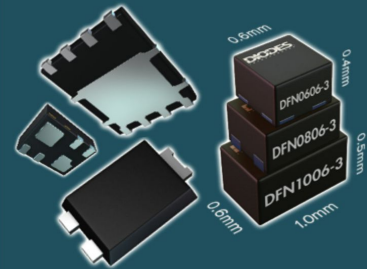

DISCRETE
ANALOG
LOGIC
MIXED-SIGNAL

Wafer Fabs

- US: South Portland, Maine
- China: Shanghai and Wuxi
- Taiwan: Hsinchu and Keelung
- UK: Greenock and Oldham
- Bipolar, BiCMOS, CMOS and BCD process
- Global footprint with strong engineering capabilities



Assembly and Test

- China: Shanghai, Chengdu, and Wuxi
- Taiwan: Jhongli
- Germany: Neuhaus



DISCRETE
ANALOG
LOGIC
MIXED-SIGNAL

By Channel

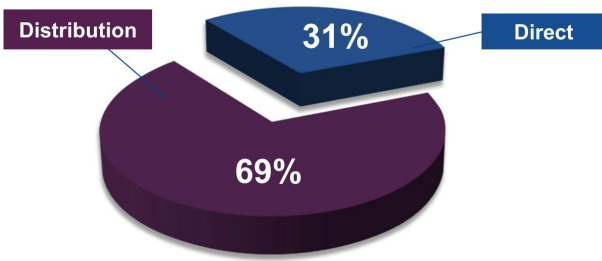

By Region

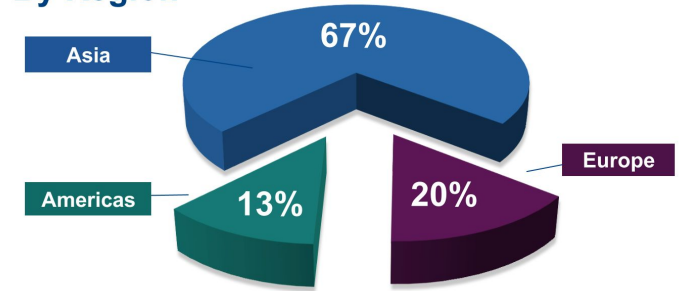

By End Market

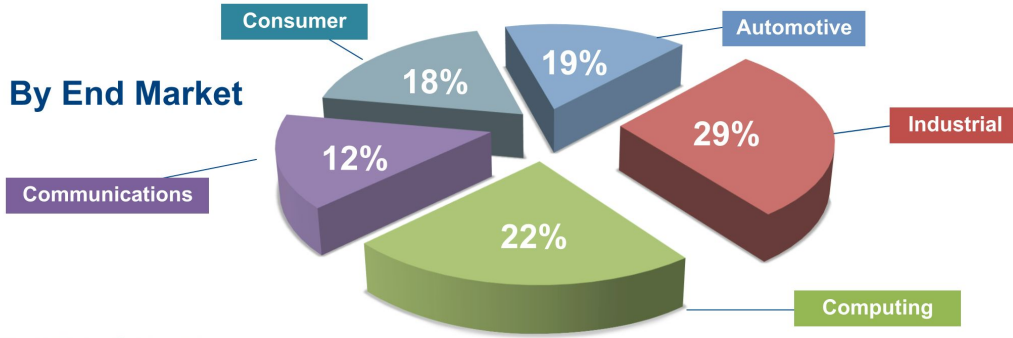

DISCRETE
ANALOG
LOGIC
MIXED-SIGNAL

Income Statement – Second Quarter 2023

(\$ in millions, except per share amounts)	2Q22	1Q23	2Q23
Net sales	501.0	467.2	467.2
Gross profit (GAAP)	206.5	194.5	195.4
Gross profit margin % (GAAP)	41.2%	41.6%	41.8%
Net income (GAAP)	80.2	71.2	82
Net income (non-GAAP)	86.9	73.4	73.3
Diluted EPS (non-GAAP)	1.90	1.59	1.59
Cash flow from operations	85.0	99.8	92.6
EBITDA (non-GAAP)	130.4	121.8	133.5



DISCRETE
ANALOG
LOGIC
MIXED-SIGNAL

(\$ in millions)	Dec 31, 2021	Dec 31, 2022	June 30, 2023
Cash*	373	348	334
Inventory	349	360	326
Current Assets	1,188	1,162	1,160
Total Assets	2,194	2,288	2,341
Total Debt	301	185	89
Total Liabilities	892	705	610
Total Equity	1,303	1,583	1,731

* Cash, Restricted Cash and Short-term investments



DISCRETE
ANALOG
LOGIC
MIXED-SIGNAL

- Revenue to be ~\$425 million, +/- 3.0%
- GAAP gross margin of 40%, +/- 1%
- Non-GAAP operating expenses 23.0% of revenue, +/- 1%, which are GAAP operating expenses adjusted for amortization of acquisition-related intangible assets
- Net Interest expense of ~\$1.0 million
- Income tax rate to be 20%, +/- 3%
- Shares used to calculate diluted EPS approximately 46.7 million
- Amortization of acquisitions-related intangible assets of \$3.1 million, after tax, for previous acquisitions is not included in these non-GAAP estimates

- **Vision: Expand shareholder value**
- **Mission: Profitability growth to drive 20%+ operating profit**
- **Next Strategic Goal: \$1B gross profit**
- **Tactics:**
 - Total system solutions sales approach and content expansion driving growth
 - Increased focus on high-margin Automotive, Industrial, analog, and power discrete products
 - Investment for technology leadership in target products, fab processes, and advanced packaging



DISCRETE
ANALOG
LOGIC
MIXED-SIGNAL

DIODES
INCORPORATED

Thank you

www.diodes.com