

UNITED STATES
SECURITIES AND EXCHANGE COMMISSION
WASHINGTON, D.C. 20549

FORM 8-K

CURRENT REPORT

Pursuant to Section 13 or 15(d) of the Securities Exchange Act of 1934

Date of Report (Date of earliest event reported): November 04, 2021

DIODES INC

(Exact name of Registrant as Specified in Its Charter)

Delaware
(State or Other Jurisdiction
of Incorporation)

002-25577
(Commission File Number)

95-2039518
(IRS Employer
Identification No.)

4949 Hedgcoxe Road, Suite 200
Plano, Texas
(Address of Principal Executive Offices)

75024
(Zip Code)

Registrant's Telephone Number, Including Area Code: 972 987-3900

(Former Name or Former Address, if Changed Since Last Report)

Check the appropriate box below if the Form 8-K filing is intended to simultaneously satisfy the filing obligation of the registrant under any of the following provisions:

- Written communications pursuant to Rule 425 under the Securities Act (17 CFR 230.425)
- Soliciting material pursuant to Rule 14a-12 under the Exchange Act (17 CFR 240.14a-12)
- Pre-commencement communications pursuant to Rule 14d-2(b) under the Exchange Act (17 CFR 240.14d-2(b))
- Pre-commencement communications pursuant to Rule 13e-4(c) under the Exchange Act (17 CFR 240.13e-4(c))

Securities registered pursuant to Section 12(b) of the Act:

Title of each class	Trading Symbol(s)	Name of each exchange on which registered
Common Stock, Par Value \$0.66 2/3	DIOD	The NASDAQ Stock Market LLC

Indicate by check mark whether the registrant is an emerging growth company as defined in Rule 405 of the Securities Act of 1933 (§ 230.405 of this chapter) or Rule 12b-2 of the Securities Exchange Act of 1934 (§ 240.12b-2 of this chapter).

Emerging growth company

If an emerging growth company, indicate by check mark if the registrant has elected not to use the extended transition period for complying with any new or revised financial accounting standards provided pursuant to Section 13(a) of the Exchange Act.

Item 8.01 Other Events.

From time to time, Diodes Incorporated (the "Company") may give corporate presentations to its customers, suppliers and other related interested parties. Copies of the Company's corporate presentation slides, updated on November 4, 2021, are attached herewith as Exhibit 99.1.

Forward-Looking Statements

The Presentation attached to this Current Report on Form 8-K as Exhibit 99.1 contains forward-looking statements that involve future risks and uncertainties as contemplated by the safe harbor provided by the Private Securities Litigation Reform Act of 1995. All statements, other than statements of historical facts, included in Exhibit 99.1 should be regarded as "forward-looking statements" and Exhibit 99.1 contains a more detailed listing of the risks and uncertainties associated with those forward-looking statements. Diodes undertakes no obligation to update publicly any forward-looking statements, whether as a result of new information, future events or otherwise

Item 9.01 Financial Statements and Exhibits.

(d) Exhibits.

Exhibit Number	Description
99.1	Corporate Presentation Slides
104	Cover Page Interactive Data File (embedded within the Inline XBRL document).

SIGNATURES

Pursuant to the requirements of the Securities Exchange Act of 1934, the registrant has duly caused this report to be signed on its behalf by the undersigned thereunto duly authorized.

DIODES INCORPORATED

Date: November 4, 2021

By: /s/Brett R. Whitmire
Brett R. Whitmire
Chief Financial Officer

Investor Relations Presentation

Plano, TX

November 2021



www.diodes.com

Any statements set forth herein that are not historical facts are forward-looking statements that involve risks and uncertainties that could cause actual results to differ materially from those in the forward-looking statements. Such forward-looking statements include, but are not limited to, statements regarding updates to Diodes Incorporated's fourth quarter 2021 business outlook as of November 3, 2021, which include the following: expect revenue to be approximately \$476 million, plus or minus 3.0 percent; expect GAAP gross margin to be 38.7 percent, plus or minus 1 percent; non-GAAP operating expenses, which are GAAP operating expenses adjusted for amortization of acquisition-related intangible assets, are expected to be approximately 21.0 percent of revenue, plus or minus 1 percent; expect non-GAAP net interest expense to be approximately \$1.2 million; expect tax rate to be 18 percent, plus or minus 3 percent; shares used to calculate diluted EPS for the fourth quarter are anticipated to be approximately 46.2 million; purchase accounting adjustments for Pericom and previous acquisitions of \$3.4 million after tax are not included in these non-GAAP estimates; and other statements identified by words such as "estimates," "expects," "projects," "plans," "will," and similar expressions.

Potential risks and uncertainties include, but are not limited to, such factors as: the risk that the COVID-19 pandemic may continue and have a material adverse effect on customer demand and staffing of our production, sales, and administration facilities; the risk that such expectations may not be met; the risk that the expected benefits of acquisitions may not be realized or that integration of acquired businesses may not continue as rapidly as we anticipate; the risk that the cost, expense, and diversion of management attention associated with the Lite-On Semiconductor Corp. acquisition may be greater than we currently expect; the risk that we may not be able to maintain our current growth strategy or continue to maintain our current performance, costs, and loadings in our manufacturing facilities; the risk that we may not be able to increase our automotive, industrial, or other revenue and market share; risks of domestic and foreign operations, including excessive operation costs, labor shortages, higher tax rates, and our joint venture prospects; the risk that we may not continue our share repurchase program; the risks of cyclical downturns in the semiconductor industry and of changes in end-market demand or product mix that may affect gross margin or render inventory obsolete; the risk of unfavorable currency exchange rates; the risk that our future outlook or guidance may be incorrect; the risks of global economic weakness or instability in global financial markets; the risks of trade restrictions, tariffs, or embargoes; the risk of breaches of our information technology systems; and other information, including the "Risk Factors" detailed from time to time in Diodes' filings with the United States Securities and Exchange Commission.

This presentation also contains non-GAAP measures. See the Company's press release on November 3, 2021 titled, "Diodes Incorporated Reports Third Quarter 2021 Financial Results" for detailed information related to the Company's non-GAAP measures and a reconciliation of GAAP net income to non-GAAP net income.



DISCRETE
ANALOG
LOGIC
MIXED-SIGNAL

Dr. Keh-Shew Lu

Chairman, President and CEO

Experience:

- Texas Instruments 27 years
 - Senior Vice President of TI Worldwide Analog and Logic
 - President of Texas Instruments – Asia

Education:

- Doctorate and Master's Degree in Electrical Engineering
Texas Tech University
- Bachelor's Degree in Engineering
National Cheng Kung University – Taiwan



DISCRETE
ANALOG
LOGIC
MIXED-SIGNAL

Gurmeet Dhaliwal

Company spokesperson
Director, Investor Relations

Experience:

- Head of Corporate Marketing, Diodes Incorporated, Milpitas, CA
- Head of Corporate Marketing, Pericom, Milpitas, CA
- Vice President, Marketing, CA Technologies (Broadcom), Redwood City, CA
- Director, Global Marketing Strategy, EMC, Pleasanton, CA
- Director, Marketing, Zarlink Semiconductor (Microchip), San Jose, CA
- Marketing Management positions at Cisco and National Semiconductor, CA

Education:

- MBA, Marketing/Entrepreneurship, Saint Mary's College of California
- BS in Electrical and Computer Engineering, UC Santa Barbara



DISCRETE
ANALOG
LOGIC
MIXED-SIGNAL

Diodes delivers high-quality semiconductor products to the world's leading companies in the consumer electronics, computing, communications, industrial, and automotive markets



Vision: Profitability Growth to Maximize Shareholder Value

Our Core Values: Integrity, Commitment, Innovation



DISCRETE
ANALOG
LOGIC
MIXED-SIGNAL

Global Operations and World-class Manufacturing & Packaging

- NASDAQ: DIOD; Founded in 1959
- Headquartered in Plano, TX; 31 locations globally
- Manufacturing in UK, Germany, China, and Taiwan
- ISO 9001:2015 Certified / IATF 16949:2016 Certified
- ISO 14001:2015 Certified
- Key acquisitions:
 - Lite-On Semiconductor – Nov. 2020
 - TI Greenock fab - April 2019
 - Pericom Semiconductor – Nov. 2015
 - BCD Semiconductor - March 2013
 - Power Analog Microelectronics (PAM) - Oct. 2012
 - Zetex - June 2008
 - Advanced Power Devices - Nov. 2006
 - Anachip Corporation Taiwan - Jan. 2006
- Over 9,000 employees worldwide
- 29 consecutive years of profitability



DISCRETE
ANALOG
LOGIC
MIXED-SIGNAL



DISCRETE
ANALOG
LOGIC
MIXED-SIGNAL

We view sustainability as a competitive advantage and have adopted a sustainability-oriented approach to assess and address related risks that may influence our operational activities, business results, and financial performance.



- Key focus areas regularly reviewed by our Board of Directors
- Instituted a cross-functional Sustainability Steering Team to address the sustainability related risks and opportunities
- The Sustainability Steering Team provides periodic updates to the Board of Directors



DISCRETE
ANALOG
LOGIC
MIXED-SIGNAL

Please refer to [Governance and Oversight](#) for additional details

Board's Oversight of Risk Management

- Robust standing committee structure and board self-evaluation process
- Active engagement with the management team to identify and assess risks
- Broad industry experience of the directors helps anticipate emerging and interrelated risks and facilitate effective risk control and mitigation mechanisms
- Director access to Company employees and independent advisors

Rigorous Corporate Governance Guidelines and Policies

- Stockholder Nominating Procedures
- Director Selection Criteria and Retirement Age Policy
- Stock Ownership Policy and Stock Holding Policy
- Foreign Exchange Risk Management Policy (also referred to as the Hedging Policy)

Diverse Board Representation

- Seven (7) out of our eight (8) directors are independent directors
- Gender, racial, and ethnic diversity reflected on board representation
- Two (2) female directors

Board of Directors Diversity Profile

Gender		
Male	6	75%
Female	2	25%
Total	8	100%

Race		
White	2	25%
Asian	6	75%
Total	8	100%

Country of Residence		
USA	4	50%
Taiwan	4	50%
Total	8	100%

- Broad set of director skills, expertise, and industry backgrounds
- Zero percent of the board has familial relationships with other directors
- Limits on director over-boarding



DISCRETE
ANALOG
LOGIC
MIXED-SIGNAL

- **Performance goals based on both Company performance goals and individual objectives:**
 - Bonus based on Revenue, Non-GAAP Earnings Per Share, and ESG
 - PSU's based on cumulative 3 year Operating Income
- **Alignment between executive compensation and stockholder interests**
- **No special grants were made to executive officers, including CEO, during the last fiscal year (2020)**
- **Annual compensation review and stockholder approval**
- **Independent Compensation Committee and independent compensation consultant**
- **Recoupment of Executive Compensation Policy**



DISCRETE
ANALOG
LOGIC
MIXED-SIGNAL

Continued Outperformance of Served Markets



DISCRETE
ANALOG
LOGIC
MIXED-SIGNAL

Revenue for 2021 is based on Q1 -Q3 result and Q4 guidance

- Goal 1: \$1B Market Cap ✔ 2010
- Goal 2: \$1B Annual Revenue ✔ 2017
- Goal 3: \$1B Gross Profit
- Goal 4: \$1B Profit Before Tax

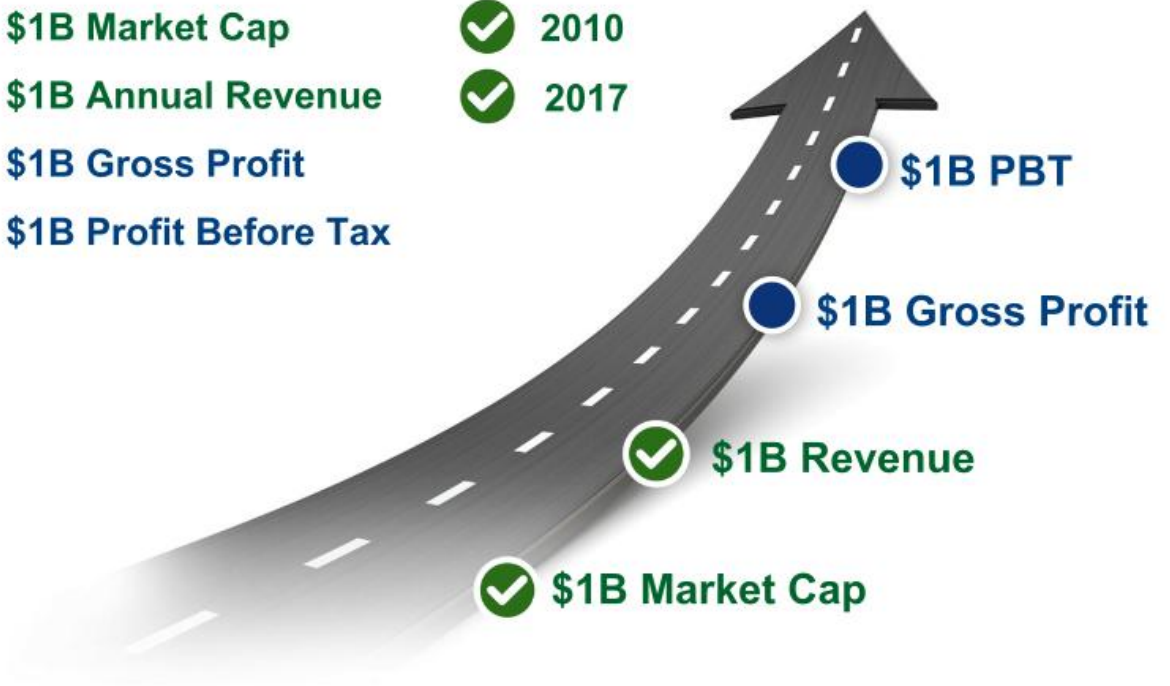

DISCRETE
ANALOG
LOGIC
MIXED-SIGNAL

Mission:

Profitability growth to
expand shareholder value

Strategy:

Grow Revenue to \$2.5B
at 40% Gross Margin

Goal:

\$1B Gross Profit by 2025



DISCRETE
ANALOG
LOGIC
MIXED-SIGNAL

~40% of
revenue
(34% for 2020)

Automotive

- Connected driving, comfort/style/safety, electrification/powertrain

Industrial

- Embedded systems and precision controls

~60% of
revenue

Consumer

- IoT: wearables, home automation, smart infrastructure

Communications

- Smartphones: advanced protocols and charging

Computing

- Cloud computing: server, storage, data centers



DISCRETE
ANALOG
LOGIC
MIXED-SIGNAL

Focus Applications:

Connected Driving

- ADAS (Advanced Driver Assistance Systems)
- Telematics
- Infotainment Systems

Comfort, Style, and Safety

- Lighting
 - Migration to LED and intelligent illumination
- BLDC motor control
 - Migration from Brushed to Brushless DC Motors

Electrification/Powertrain

- Conventional Powertrain → Hybrid → Electrification
- Battery management
 - Move to 48V battery

Diodes Automotive Revenue Year over Year Increase

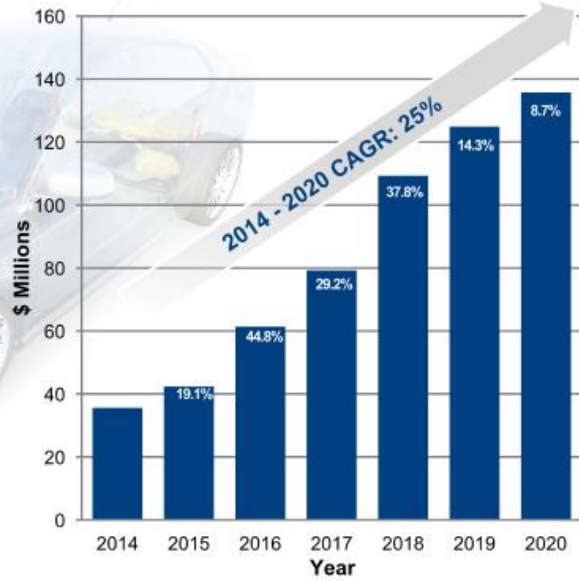

DISCRETE
ANALOG
LOGIC
MIXED-SIGNAL

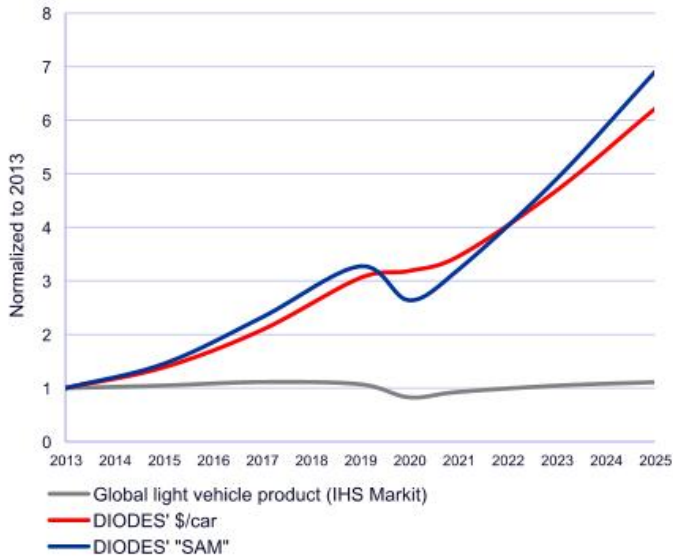

Car & LV Volumes – IHS Markit 2020
 DIODES' SAM = volume * \$/car



2021 Automotive Potential Revenue	\$/ Car
Automotive Motor Control	\$39.57
Connected Driving (Infotainment, Telematics & ADAS)	\$30.97
Powertrain, Electrification & Body Control Electronics	\$14.77
Lighting – Moving to LED	\$11.23
Total	\$96.54



DISCRETE
 ANALOG
 LOGIC
 MIXED-SIGNAL

- Increasing IC content in embedded systems
- Switching and signal path for networked systems and automation
- Signal conditioning and timing for precision controls
- Motor controls, sensors, and power management for smart meters

Industrial Revenue

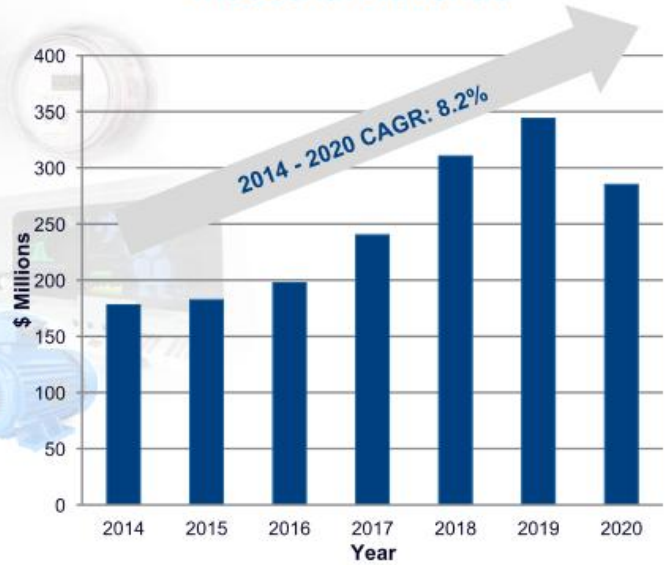

For 2020, 23% of total revenue is from Industrial market



DISCRETE
ANALOG
LOGIC
MIXED-SIGNAL

- **M2M – Dominated by short range technology**
 - 73% are short range, mostly Wi-Fi
- **2017: connections @ 750 million**
- **2023: connections @ 2600 million**

M2M – By Product

- IoT and M2M Modems
- Routers
- POS
- AGV (Automated Guided Vehicle)
- UAV (Unmanned Aerial Vehicle)

M2M – By Application

- Smart Infrastructure
- POS
- Manufacturing / Industrial

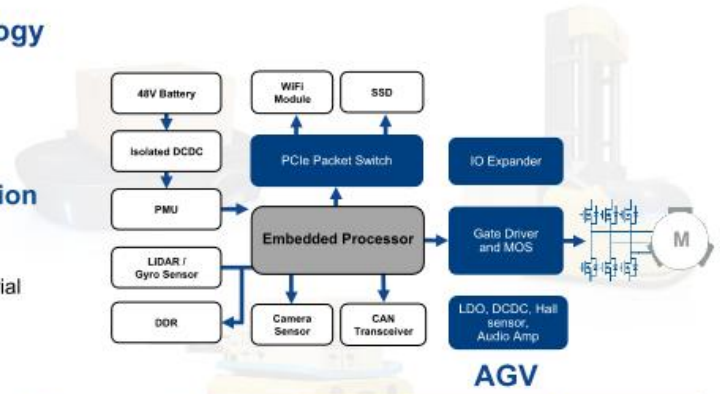

AGV

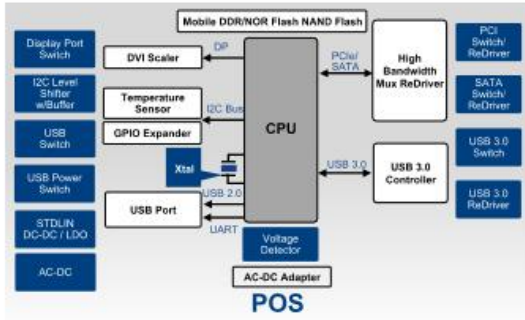

POS

Growth Opportunities:

- Power, Sensor, DC-DC
- Gate Driver, BJT, MOSFET
- XTAL and clock
- Packet switch, IO Expander

Diodes Key Products	\$ / AGV
Discrete	\$3.5
Analog	\$0.4
Timing and Connectivity	\$10.4
Total	\$14.3



DISCRETE
ANALOG
LOGIC
MIXED-SIGNAL

Smart Infrastructure

Consumer & Home

Wearables

Asset Tracking

DIODES INCORPORATED

Retail

Enterprise

Security & Surveillance

Consumer Revenue (\$M)

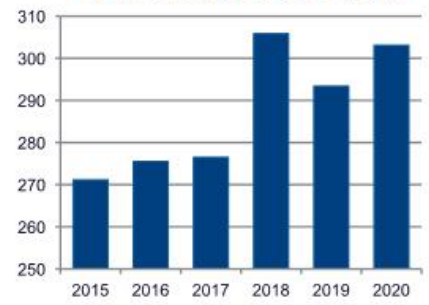

Diodes Key Products	\$ / Box
Analog	>\$0.20
Power Management	>\$1.30
MOS/BJT	>\$10.00
Diodes and Rectifiers	>\$5.00
Timing and Connectivity	\$3.50
Total	\$20.00



DISCRETE
ANALOG
LOGIC
MIXED-SIGNAL

Smart Home – expected to grow to 1.4Bu by 2023

- Safety and Security
- Climate Control
- Consumer Electronics
- Lighting control

Growth Opportunities

- Power
- LED driver
- Xtal and clock
- Packet switch



Diodes Key Products	\$ / Box
Analog	\$0.40 ~ \$0.65
Power Management	\$1.80
MOS/BJT	\$1.10
Diodes and Rectifiers	\$0.50
Timing and Connectivity	\$3.50
Total	\$7.55

Smart Home Gateway

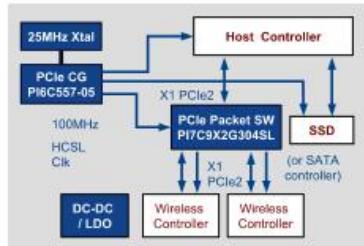

Smart Lighting

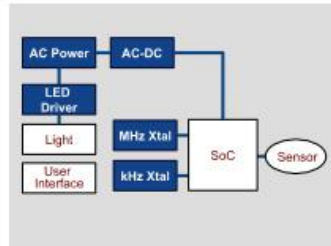

Smart Speaker

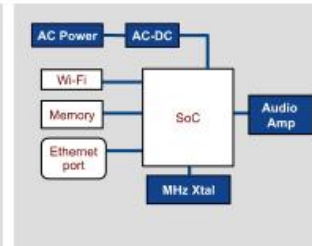

Digital Assistant

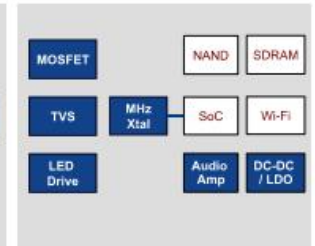

DISCRETE
ANALOG
LOGIC
MIXED-SIGNAL

Driving Smartphone Growth

- Smart speaker/IoT rising
- AR / VR
- Foldable screens
- 5G
- Smartwatches

Growth Opportunities

- USB Type-C
- MUX
- MOSFET
- LDO, OVP, LDSW, Audio, DCDC, LED/OLED Driver, ACDC

Diodes Key Products	\$ / Phone
Analog	\$0.55
Power Management	\$1.50
MOS/BJT	\$0.33
Diodes and Rectifiers	\$0.42
Timing and Connectivity	\$3.00
Total	\$5.80

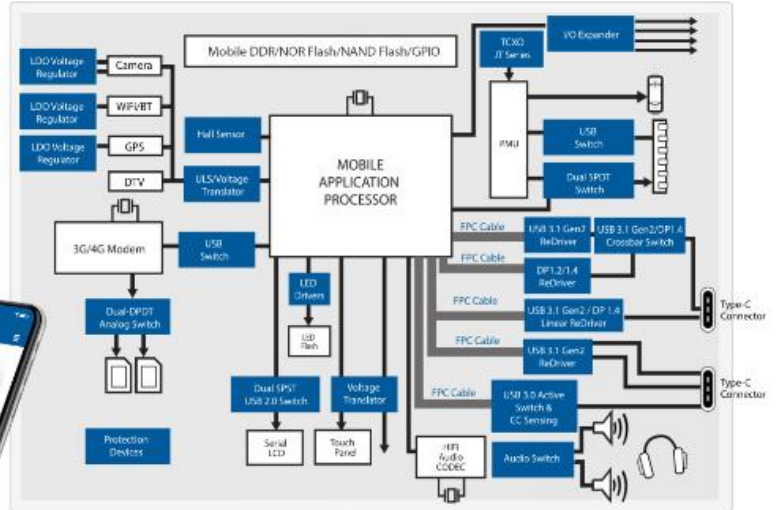

DISCRETE
ANALOG
LOGIC
MIXED-SIGNAL

- ReDriver support for USB connectivity
- Wide range of signal protocols: PCIe, SAS, SATA, GbE, USB
- MUX products for high capacity solid state storage
- Crystal oscillators for increasing clocking speeds
- LDOs, SBR, and TVS for power management and protection



DISCRETE
ANALOG
LOGIC
MIXED-SIGNAL

Server Platform Solution

- CAGR is 5% (2020-2024)
- Almost all of Server vendors are Diodes existing customers
- Diodes products are well positioned in this segment
 - Connectivity, Signal Integrity, Timing, Standard Linear, Power Management, Power Switches, Protection or HV MOSFET / SBR devices

WW Server total shipments (Mu)

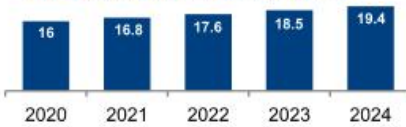

Diodes Key Products	\$ / Server
Analog	2.31
Discrete	3.41
Timing and Connectivity	23.34
Total	\$29.06

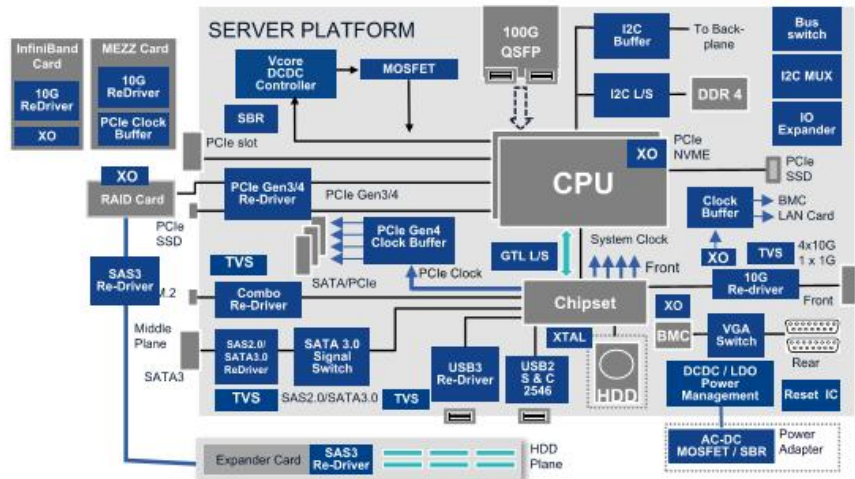

DISCRETE
ANALOG
LOGIC
MIXED-SIGNAL

Data speed, flexibility, and simplicity of use are key drivers

Focus Applications:

- Smartphone, Tablet
- NB/DT/WS/AIO, PC, Server
- CE Appliance
- PC Peripheral/Monitor
- Inflight Entertainment
- Automotive - Infotainment
- Robotics
- Chargers

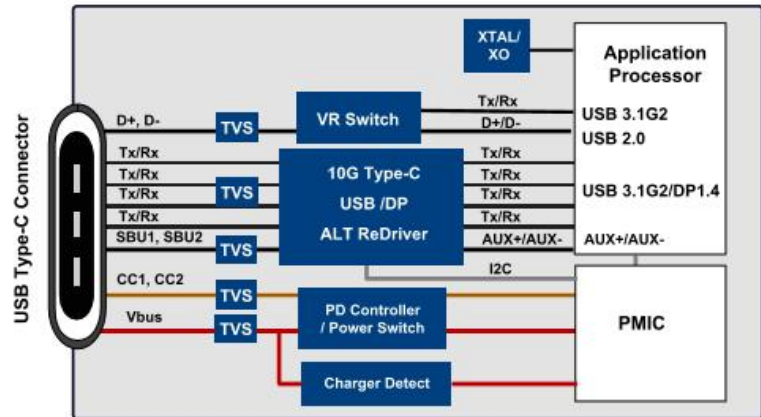

Supports data, video, and power



DISCRETE
ANALOG
LOGIC
MIXED-SIGNAL

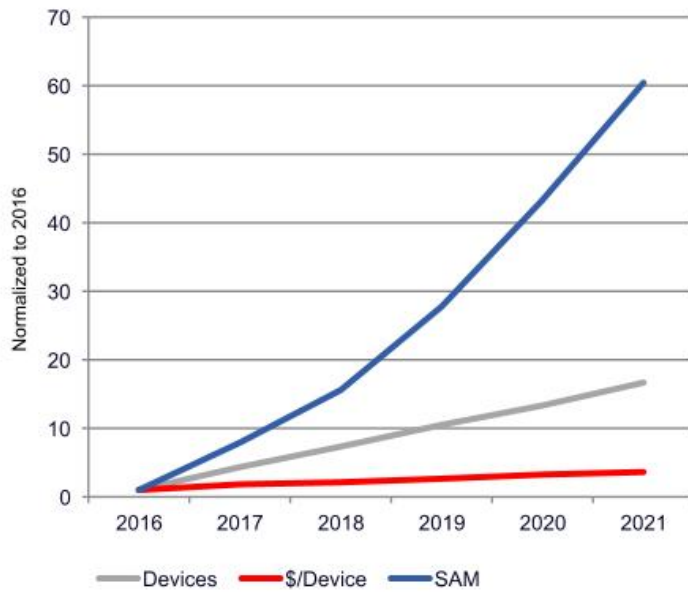

2021 Automotive Potential Revenue	\$ / Car
Connectivity, Signal Integrity and Timing	\$3.25
Analog (DCDC, LDO, Sleep Mode Charger etc)	\$0.89
Power Management Switch	\$0.40
MOSFET/BJT	\$0.25
Diodes, Rectifiers and TVS	\$0.50
Total	\$5.29

■ **USB-C adoption to grow from 300M (2016) to 5B units (2021)**

- IHS Dec 2017



DISCRETE
ANALOG
LOGIC
MIXED-SIGNAL

Focus Applications:

Cloud Computing

- Data Center Server

Gateway

- Internet Gateway
- Fiber network

Core Network, Cell Stations

- Small Cells
- Base Station
- Edge Computing Server
- Smart antenna
- Fiber network

End Products

- Portables: Smartphone, Tablet
- Smart Car
- Consumer: VR/AR, Drone, IoTs
- Telecom: 5G CPEs
- Embedded/Industrial

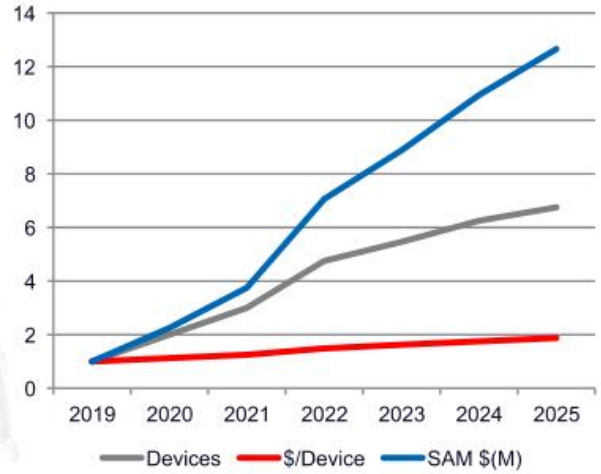

Diodes Key Products	\$ / System
Precision Timing & Connectivity	\$5.00 ~ \$10.00
Discrete	\$2.03 ~ \$2.50
Analog	\$9.00 ~ \$11.28
Total	\$16.03 ~ \$23.78



DISCRETE
ANALOG
LOGIC
MIXED-SIGNAL

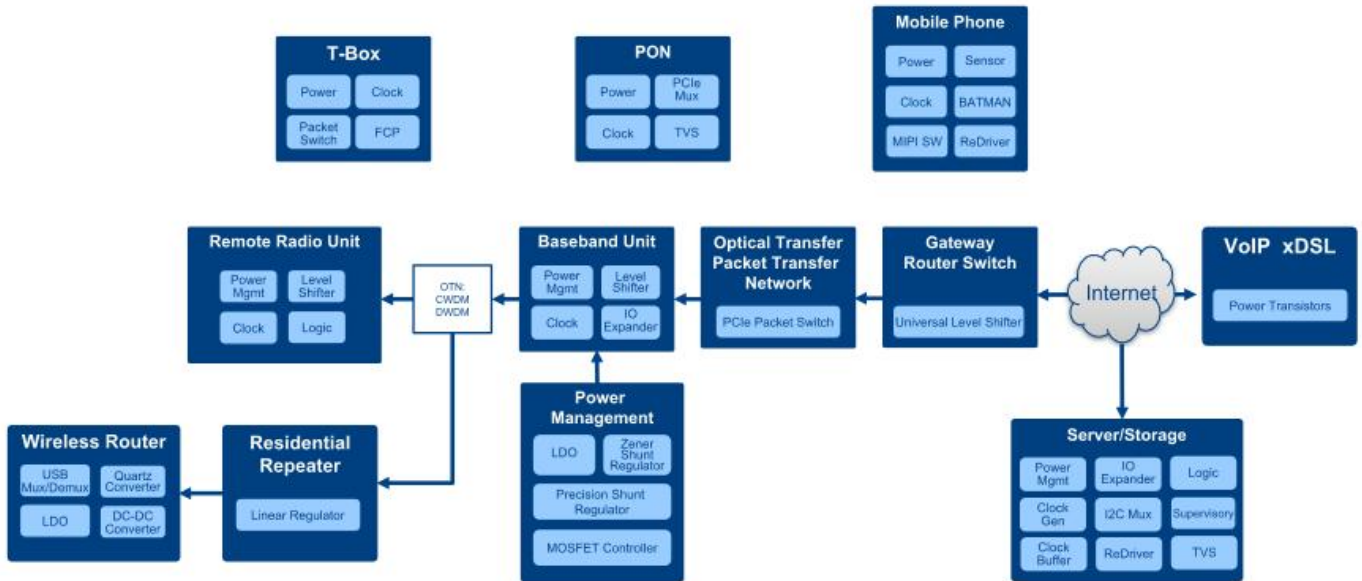

DISCRETE
ANALOG
LOGIC
MIXED-SIGNAL

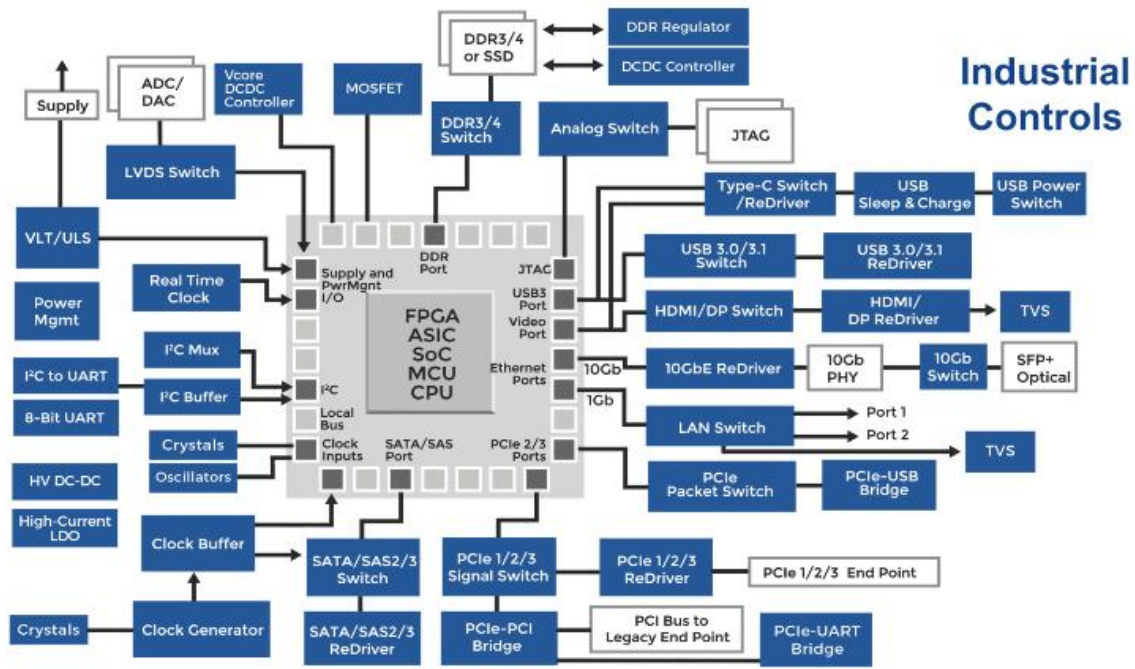

DISCRETE
ANALOG
LOGIC
MIXED-SIGNAL

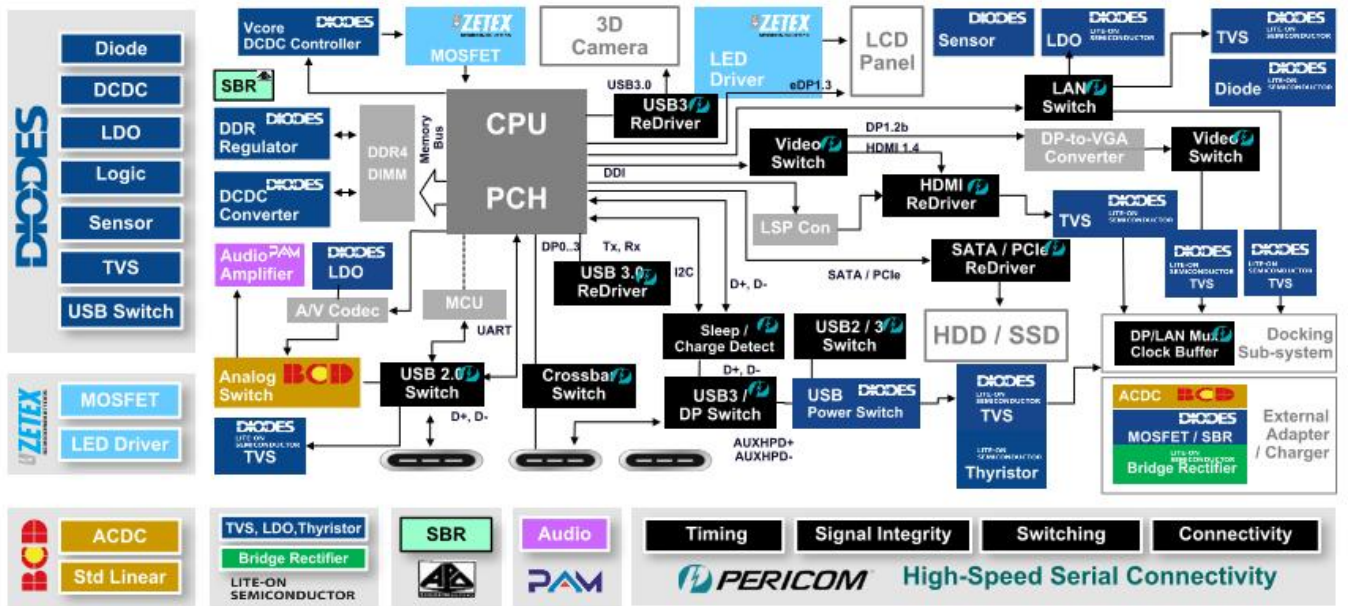

DISCRETE
ANALOG
LOGIC
MIXED-SIGNAL

Products



- 20Gbps ReDrivers and Switches
- Automotive Packet Switch for Telematics / ADAS
- Complete USB Type-C Signal Switching
- High speed clocking for cloud computing
- Ultra low power and low noise LDOs for IoT
- Low C_j TVS for signal integrity
- Lowest $R_{DS(ON)}$ LDMOS for battery efficiency

Wafer Fab

- High performance 8" MOSFET trench technology
- Advanced Epi bipolar transistor processes
- Proprietary rectifier technology
- Rugged automotive grade NMOS and PMOS

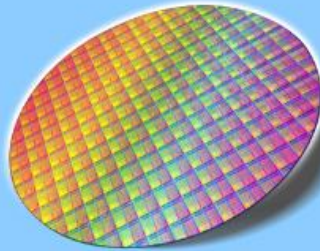

Assembly/Test

- Compact QFN and DFN
- Power density PowerDI
- Chip scale packaging and plating capability
- Extensive multi-chip package technology

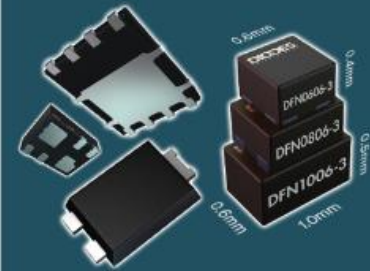

DISCRETE
ANALOG
LOGIC
MIXED-SIGNAL

Focus: Miniaturization and Power Efficiency



DISCRETE
ANALOG
LOGIC
MIXED-SIGNAL

Miniaturization and Multi-Chip Packaging

Miniaturization

DDFN0402

the smallest discrete semiconductor package

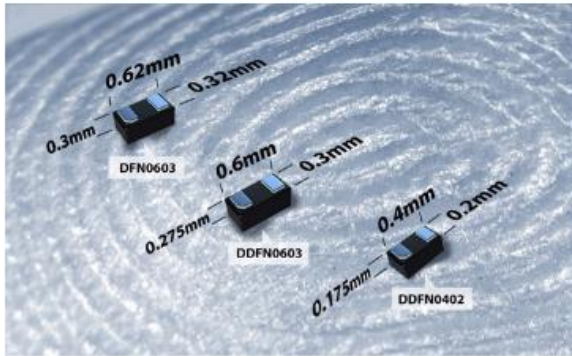

Multi-Chip Packaging

Dual-Flat No-Lead (DFN)

DDFN (Encapsulated CSP)

Chip-Scale Package (CSP)

HS IntelliFET: ZXMS3001

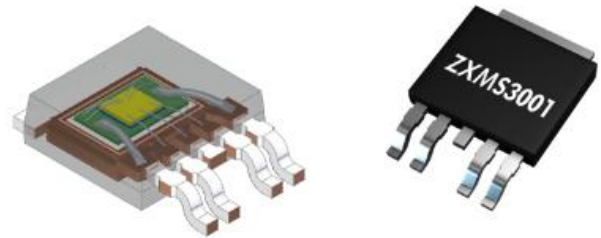

DISCRETE
ANALOG
LOGIC
MIXED-SIGNAL

Packaging

- Shanghai-based packaging with capacity over 34 billion units
- Chengdu facility has potential capacity 3X of Shanghai
- Additional facilities in Neuhaus, Germany and Wuxi, China



Wafer Fabs

- China fabs in Shanghai and Wuxi, Taiwan fabs in Hsinchu and Keelung, and UK fabs in Greenock and Oldham
- Bipolar, BiCMOS, CMOS and BCD process
- Strong engineering capabilities



Economies of Scale: Package Capacity & Loading Percentage in SAT & CAT

*CapEx Model = 5% - 9% of Revenue

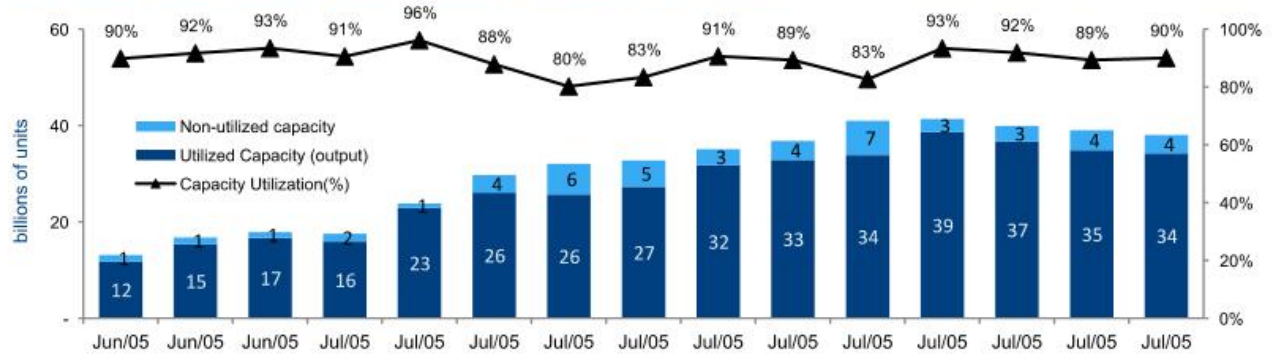

DISCRETE
ANALOG
LOGIC
MIXED-SIGNAL

(\$ in millions, except per share amounts)	3Q20	2Q21	3Q21
Net sales	309.5	440.4	471.4
Gross profit (GAAP)	111.1	159.8	181.2
Gross profit margin % (GAAP)	35.9%	36.3%	38.4%
Net income (GAAP)	27.2	55.4	68.4
Net income (non-GAAP)	32.8	54.6	67.3
EPS (non-GAAP)	0.62	1.20	1.47
Cash flow from operations	39.7	93.9	98.9
EBITDA (non-GAAP)	63.3	99.4	114.5



DISCRETE
ANALOG
LOGIC
MIXED-SIGNAL

(\$ in millions)	Dec 31, 2019	Dec 31, 2020	Sept 30, 2021
Cash/Cash equivalents/restricted cash plus short-term investments	264	327	292
Inventory	236	307	322
Current Assets	810	1,024	1,064
Total Assets	1,639	1,980	2,042
Total Debt (L/T, S/T, Line of Credit)	111	451	252
Total Liabilities	487	963	825
Total Equity	1,153	1,016	1,217



DISCRETE
ANALOG
LOGIC
MIXED-SIGNAL

By Channel

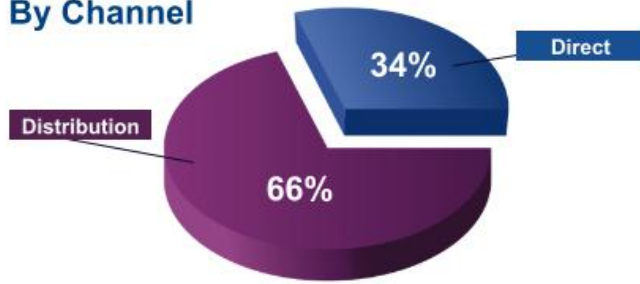

By Region

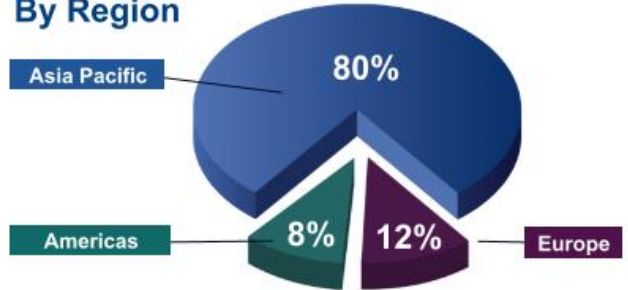

By End Market

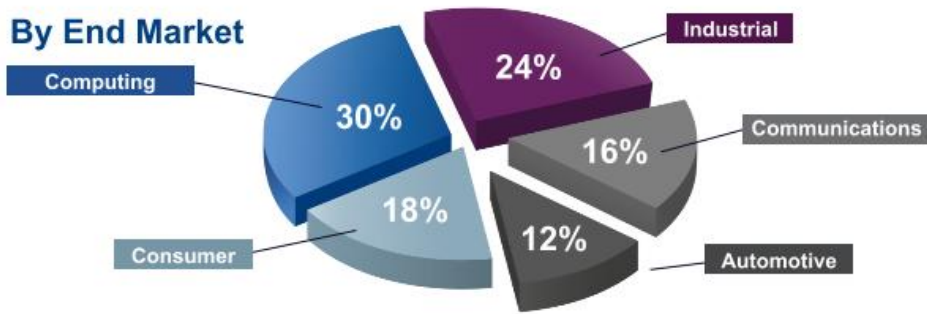

DISCRETE
ANALOG
LOGIC
MIXED-SIGNAL

- **Revenue to increase to ~\$476 million, +/- 3.0%**
 - A record on both an organic and consolidated basis for a combined increase of about 6% sequentially at the mid-point
- **GAAP gross margin of 38.7%, +/- 1%** on a consolidated basis
- **Non-GAAP operating expenses 21.0% of revenue, +/- 1%**, which are GAAP operating expenses adjusted for amortization of acquisition-related intangible assets
- **Net Interest expense of ~\$1.2 million**
- **Income tax rate to be 18%, +/- 3%**
- Shares used to calculate diluted EPS approximately **46.2 million**
- Purchase accounting adjustments related to amortization of acquisitions-related intangible assets of \$3.4 million, after tax, for Pericom and previous acquisitions is not included in these non-GAAP estimates

**Guidance as provided on November 3, 2021*



DISCRETE
ANALOG
LOGIC
MIXED-SIGNAL

- **Vision: Expand shareholder value**
- **Mission: Profitability growth to drive 20% operating profit**
- **Next Strategic Goal: \$1B gross profit**
- **Tactics:**
 - Increased focus on high-margin Automotive, Industrial, and Pericom products
 - Investment for technology leadership in target products, fab processes, and advanced packaging
 - System solutions to drive business expansion



DISCRETE
ANALOG
LOGIC
MIXED-SIGNAL



DIODES
INCORPORATED

Thank you



www.diodes.com